

Type No. _____
 Job Name _____
 Catalog No. _____



Shown: NX2HLR

NX Series NEMA Exit Signs

- Direct View LED Illumination
- Maintenance Free, Sealed Nickel Lead Calcium Battery

Housing

- Watertight enclosure constructed of fiberglass reinforced polyester with clear polycarbonate cover
- Two head NEMA exit features fully adjustable 6 volt 6 watt halogen Par 36 sealed beam lamps which are enclosed in a watertight, reinforced polycarbonate housing
- Test switch and LED indicator light
- Available in back mount only

Battery

- Combination LED exit/emergency unit uses a maintenance free, sealed lead calcium battery with an expected service life of 5 years with an operating range of 65°F (19°C) to 85°F (30°C)*

* Increases or decreases in temperature will affect battery performance and/or capacity. Optimum battery performance realized at 77°F (25°C).

Application

- Industrial and wet locations
- The NX Series meets the Buy American requirements

Warranty

- Electronics: 3 years
- Battery: 1 year full, 4 years pro-rata

Electronics

- 120/277 VAC selectable input on most units
- Solid-state, constant current charging circuitry
- Low voltage disconnect (LVD) prevents deep discharge during extended power failure
- Labor saving AC lockout installation feature
- Brownout protection activates unit when AC voltage drops 20% below nominal

Electrical Specifications

- Exit Combo: 0.161 amps (120 VAC), 0.07 amps (277 VAC)

Code Compliance

- UL 924
- UL damp location listing optional, UL wet location listing optional -22°F (-30°C) to 104°F (40°C)
- NFPA 101, NEC, BOCA, OSHA, and IBC illumination standards
- NSF listing standard 2 "Splash Zone"

Dimensions

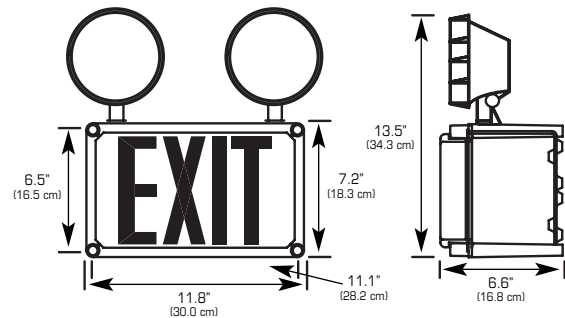

Dimensions are approximate and subject to change.

NX Series, NEMA Exit Signs

Ordering Information

NX	2H	L		
SERIES	POWER REQUIREMENTS	LAMP TYPE	FACE COLOR	OPTIONS ¹
NX	2H = Combination Exit/Emg., Lead Calcium	L = LED	R = Red LEDs G = Green LEDs	EX = Special Input Transformer ¹ F = 24 VDC Fire Alarm Interface FL = Emergency Flasher S = Shatter Resistant Lamp Head Lens TP = Tamperproof Lockup ² W = Wet Location Listing Z = Damp Location Listing

ACCESSORIES (Ordered Separately)
EMF = External Mounting Feet

NOTES: 1) Some option combinations may impact UL listing. Consult factory for specifics. 2) Includes tamperproof hardware and bit.

Optics

Wall mounted 8' AFF, 6 Volt 6 Watt PAR 36 Lamps Represented

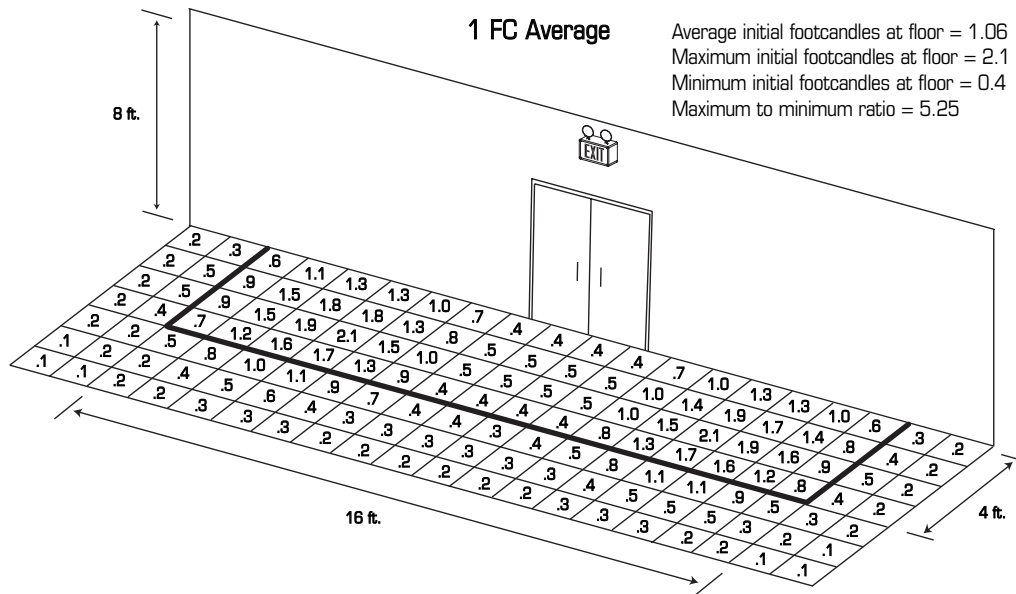

Suggested Specification

Furnish and install LightGuard's NX Series exit sign model _____. The exit shall be constructed to meet Underwriter's Laboratories, Inc. Standard #924 and the National Electrical Code (NEC).

INSTALLATION AND OPERATION - Exit shall be easily field connected to a 120 or 277 VAC, 60 hertz, unswitched power source. Installation must comply with the NEC as well as other applicable codes. Upon utility power failure or brownout, the unit shall automatically transfer to battery power and maintain the required illumination level for a minimum period of 90 minutes. Upon restoration of utility power, the charger shall restore the battery to full charge within UL 924 requirements following a rated discharge of not more than 90 minutes.

CHARGER - Product shall utilize a fully automatic, voltage regulated charging system. The charging system shall maintain the battery at full capacity without the need for periodic exercising or equalization. The following features shall be standard: low voltage disconnect (LVD), brownout protection and AC lockout.

BATTERY - The battery shall be a maintenance free, sealed lead calcium battery. The lead calcium battery shall provide trouble-free operation in temperatures up to 85°F (30°C). Sealed lead calcium batteries shall be supplied with a one year full warranty.

ILLUMINATION - The NX Series exit shall be illuminated by direct view LEDs. The LED version shall operate 87 diodes connected in parallel. Each LED panel shall consume less than 6 watts.

HOUSING - The exit sign be housed in a watertight enclosure constructed of fiberglass reinforced polyester with a clear polycarbonate cover.

ALL SPECIFICATIONS SUBJECT TO CHANGE WITHOUT NOTICE



272 West Stag Park Service Road • Burgaw, NC 28425
(910) 259-1131 • FAX (800) 403-6927
www.lightguard.com

L2045R19
9/11 IH