

Type No. _____
Job Name _____
Catalog No. _____



Shown: LN4X



LN4X Series Emergency Lighting

- Wet Location, Corrosion Resistant
- Maintenance Free, Sealed Lead Calcium Battery

Housing

- Constructed of corrosion resistant grey fiberglass, resistant to corrosive atmospheres and harsh environments
- UL Listed for wet locations
- Includes a low profile test switch and indicator light

Battery

- Maintenance free, sealed lead calcium battery has an expected service life of 5 years with an operating range of 44°F (5°C) to 104°F (40°C)*
- Battery supplies 90 minutes of emergency power

* Increases or decreases in temperature will affect battery performance and/or capacity. Optimum battery performance realized at 77°F (25°C)

Illumination

- Illumination is provided by two 6 VDC, 7.2 watt, fully adjustable Par 36 style lamp heads

Warranty

Electronics: 1 year

Battery: 1 year full, 4 years pro-rata

Electrical Specifications

120 VAC, 60 HZ, .050 A

1277 VAC, 60 HZ, .021 A

Electronics

- Universal 120/277 VAC operation
- Solid-state charging circuitry provides a reliable charging system
- Brownout protection activates lights when AC voltage drops 20% below nominal
- AC indicator lamp and test switch
- Low voltage disconnect feature (LVD) prevents deep battery discharge

Code Compliance

- UL 924 listed
- UL wet location listed, 44°F (5°C) to 104°F (40°C)
- NFPA 101, NEC, BOCA, OSHA, and IBC illumination standards

Application

- Corridors
- Open areas exposed to the environment

Ordering Information

LN4X
Series
LN4X = Corrosion Resistant Emergency Lighting Unit 6 Volt, 15 Watt Emergency Lighting Fixture

Dimensions

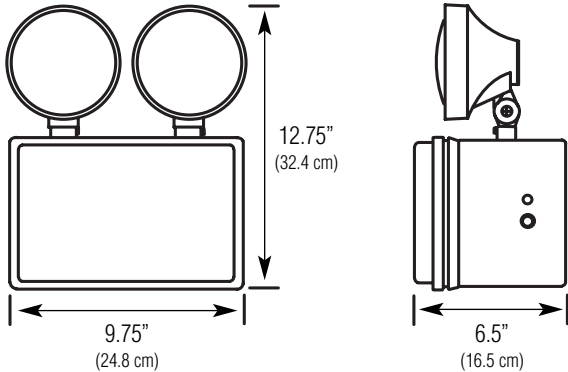

Dimensions are approximate and subject to change.

Suggested Specification

Furnish and install LightGuard's wet location emergency lighting model _____ . The unit shall be constructed to meet Underwriter's Laboratories, Inc. Standard #924 and must be installed to conform to Article 700 of the National Electrical Code (NEC).

INSTALLATION AND OPERATION - Unit shall be easily field connected to a 120 or 277 VAC, 60 hertz, unswitched power source. Installation must comply with the NEC as well as other applicable codes. Upon utility power failure or brownout, the unit shall automatically provide emergency battery power and maintain the stated illumination level and output wattage for a minimum period of 90 minutes. Upon restoration of utility power, the charging circuitry shall restore the battery to full charge within UL 924 requirements following a rated discharge of not more than 90 minutes. The unit shall be wet location listed standard.

CHARGING CIRCUITRY - Unit shall utilize a solid-state, fully automatic, voltage regulated charging system which will maintain the battery at full capacity without the need for periodic exercising or equalization. The following features shall be standard: low voltage disconnect (LVD), brownout protection and AC lockout.

BATTERY - The battery shall be maintenance free, sealed lead calcium with an optimum operating temperature range of 44°F (5°C) to 104°F (40°C). All normal gassing shall be contained within the battery casing, and will not escape into the atmosphere. Gasses created during recharge cycles will recombine with existing electrolyte. The battery shall have a recommended service life of 5 years when operated at optimum operating temperature.

ILLUMINATION - Illumination shall be provided by two 6 VDC, 7.2 watt adjustable Par36 style lamp heads.

HOUSING - The housing shall be constructed of corrosion resistant, UL 94 V-0, 5 VA grey fiberglass, including a low profile test switch and indicator light. The unit is resistant to corrosive atmospheres, harsh environments and is UL listed for wet locations.

ALL SPECIFICATIONS SUBJECT TO CHANGE WITHOUT NOTICE



272 West Stag Park Service Road • Burgaw, NC 28425
(910) 259-1131 • FAX (800) 403-6927
www.lightguard.com

L2325R4
9/11 IH