

Type No. _____
Job Name _____
Catalog No. _____

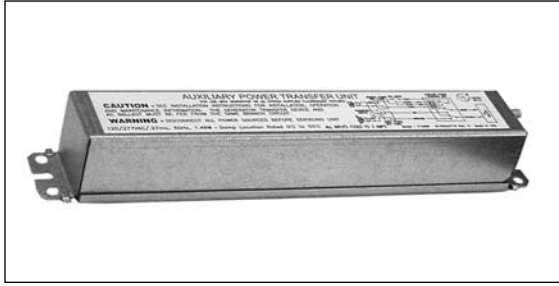

Shown: FLTC



FLTC

Fluorescent Lighting Transfer Circuit

Housing

- Housing and cover are constructed of 24 gauge galvanized steel
- Low profile housing allows mounting in most low profile fluorescent fixtures with low profile AC ballast

Illumination

- Emergency illumination is provided to designated fluorescent fixtures by transferring backup generator or inverter power to the AC ballast
- The designated emergency fixture can be locally switched, and will provide full rated light output when operating from emergency power

Installation

- The FLTC is designed to be factory or field installed in the fixtures ballast channel or mounted on top when using the supplied end cap
- One FLTC device is required per lighting fixture

Application

- Ideal for commercial, retail, or office locations where local wall switch control of fluorescent luminaires connected to an emergency power source (generator, lighting inverter) is desired
- FLTC meets the Buy American requirements

Warranty

- Electronics: 5 years full

Electronics

- 120/277 VAC dual input voltage with all inputs fused to 3 amps

Electrical Specifications

- 120/277 VAC - .27mA - 1.48 watts
- All inputs fused to 3 amp

Code Compliance

- UL 924 "Auxiliary Power and Lighting Equipment" listed
- UL damp location listing standard
- NFPA 101, NEC, BOCA, OSHA, and IBC illumination standards

Operating Temperature Range

- 32°F (0°C) to 131°F (55°C)

FLTC - Fluorescent Lighting Transfer Circuit

Ordering Information

FLTC
SERIES
FLTC = Fluorescent Lighting Transfer Circuit

Ordering Example



Dimensions



Dimensions are approximate and subject to change.

Typical Wiring Diagram

Shown with utility power present

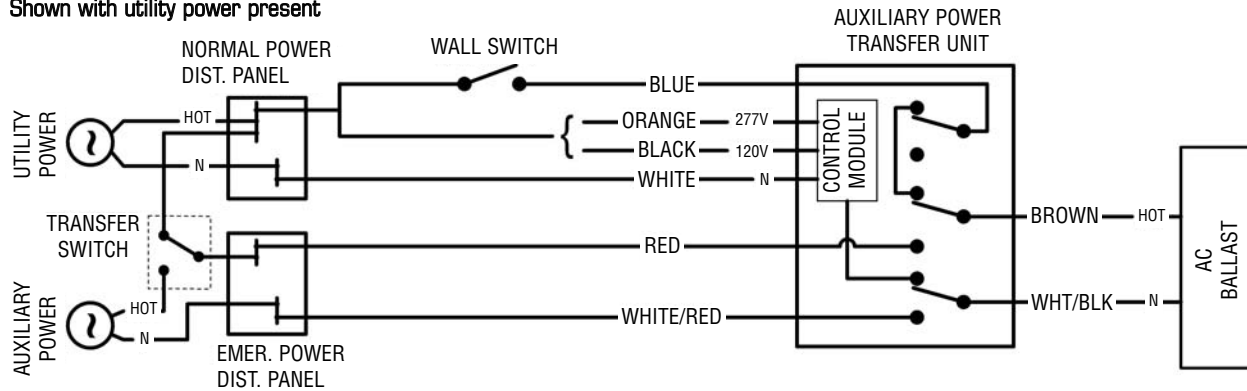

Shown with programmable circuit breakers (generator off-line)

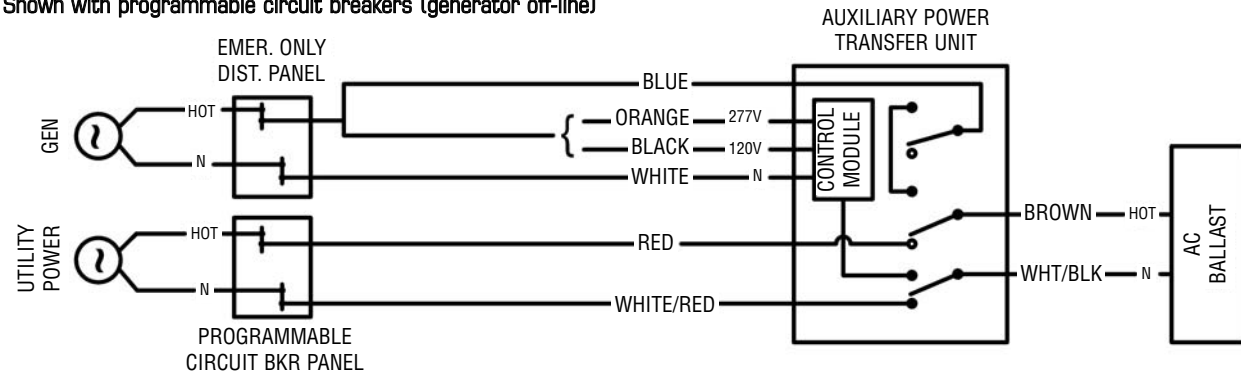

Suggested Specification

Furnish and install LightGuard model _____. The unit shall be constructed to meet Underwriters Laboratories, Inc. Standard 924 "Auxiliary Power and Lighting Equipment" and the National Electrical Code (NEC).

INSTALLATION AND OPERATION – Unit shall be easily field connected to a 120 or 277 VAC, 60 Hz, unswitched power source. Unit shall also be easily field connected to an auxiliary power source such as a generator or AC Inverter system. Installation must comply with the NEC as well as other applicable codes. Upon utility failure, the unit shall automatically transfer auxiliary power to the AC ballast and provide full lumen output from the designated emergency fixture

TRANSFER FUNCTION – Unit shall have 120/277 VAC dual input voltage and all inputs shall be fused to 3 amps. Transfer to the emergency mode shall be automatic and independent of the wall switch position.

ILLUMINATION – Unit shall be capable of transferring emergency power, from a generator or inverter directly to the AC ballast

HOUSING – Housing and cover shall be of 24 gauge galvanized steel. The unit shall be UL listed for installation in the ballast channel or on top of the fixture. The unit shall be damp location listed with an application temperature range of 32°F (0°C) to 122°F (55°C).

ALL SPECIFICATIONS SUBJECT TO CHANGE WITHOUT NOTICE



272 West Stag Park Service Road • Burgaw, NC 28425
 (910) 259-1131 • FAX (800) 403-6927
 www.lightguard.com

L2342R7
 10/10 IH