



a Genlyte company

L1400ST-N

UNIVERSAL VOLTAGE
EMERGENCY
LIGHTING EQUIPMENT

INSTRUCTION MANUAL

IMPORTANT SAFEGUARDS

When using electrical equipment, basic safety precautions should always be followed, including the following:

READ AND FOLLOW ALL SAFETY INSTRUCTIONS

1. **CAUTION** – To prevent electrical shock, do not mate unit connector until installation is complete and A.C. power is supplied to the unit.
2. **CAUTION** – This fixture provides more than one power supply output source. To reduce the risk of electrical shock, disconnect both normal and emergency sources by turning off the A.C. branch circuit and by disconnecting the unit connector.
3. **CAUTION** – This is a sealed unit. The integral, high temperature Ni-Cad battery is not replaceable. Replace the entire unit when necessary and recycle or dispose of the nickel-cadmium battery properly.
4. **DO NOT USE OUTDOORS.** The L1400ST-N is for use with grounded, UL Listed, indoor fixtures except in heated air outlets or hazardous locations.
5. The L1400ST-N requires an unswitched A.C. power source of 110-277V 50/60Hz.
6. Do not mount near gas or electric heaters.
7. The L1400ST-N should be mounted in locations and at heights where it will not readily be subjected to tampering by unauthorized personnel.
8. The L1400ST-N is suitable for mounting in the ballast compartment or on top of the fixture. For top mount, order optional mounting kit TMK-80.
9. The L1400ST-N will cold strike and operate *one* 28W or 54W T5 or 2'-8' or *two* 2'-4' instant start, rapid start, U shape or circline, T8 through T12 fluorescent lamps, including energy saving and long 4 pin compact lamps for 90 minutes.
10. The L1400ST-N is compatible with most A.C. ballasts (including multiple lamp) as follows:
Magnetic ballasts – either one or two lamp emergency operation.
Electronic ballasts – one lamp emergency operation, consult Customer Service for two lamp emergency operation wiring diagrams.
11. The use of accessory equipment not recommended by the manufacturer may cause an unsafe condition.
12. Do not use this equipment for other than intended use.
13. Install in accordance with the National Electrical Code and local regulations.
14. Installation and servicing should be performed by qualified personnel.
15. Lighting fixture manufacturers, electricians and end users need to ensure product system compatibility before final installation.

SAVE THESE INSTRUCTIONS



THIS UNIT CONTAINS A
RECHARGEABLE NICKEL-
CADMIUM BATTERY. PLEASE
RECYCLE OR DISPOSE OF
PROPERLY.

Ni-Cd

INSTALLATION INSTRUCTIONS

CAUTION: Before installing, make certain the A.C. power is off and the L1400ST-N unit connector is disconnected.

1. LAMPS OPERATED

The L1400ST-N can be used with most 2'-8' lamps. Refer to the chart below for the type of lamp(s) operated and the number of lamps to be operated in emergency mode.

OPTION	LAMP TYPE	EMERGENCY OPERATION	*VIOLET LEADS	WIRING DIAGRAMS
1	2'-4' T8/T12 Single & Bipin Pin	One Lamp	Connected	1, 2, 3, 4, 5, 6, 7, 8
2	5'-8' T8/T12 Single & Bipin Pin	One Lamp	Disconnected	1, 2, 3, 5, 6
3	2'-4' T8/T12 Single & Bipin Pin	Two Lamp	Disconnected	9, 10
4	2'-4' 28W T5	One Lamp	Connected	1, 2, 3, 4, 5, 6, 7, 8
5	2'-4' 54W T5	One Lamp	Disconnected	1, 2, 3, 4, 5, 6, 7, 8

*The 6" violet leads provide the lamp selection option. The unit is shipped from the factory with the leads disconnected and capped.

2. MOUNTING THE L1400ST-N

Remove the ballast channel cover. Mount the L1400ST-N in the ballast channel at least 1/2" away from the A.C. ballast(s). The L1400ST-N may also be mounted on top of the fixture. The optional top mounting kit (Catalog No. TMK-80) may be ordered separately from Customer Service.

3. WIRING

Refer to the wiring diagrams on the back page for the appropriate wiring of lamp(s) and ballast. Install in accordance with the National Electrical Code and local regulations. For additional wiring diagrams consult Customer Service.

4. INSTALLING THE LIGHTED PUSH BUTTON TEST SWITCH (LPTS)

Recessed Troffer Fixture – Select a convenient location with proper clearance in the ballast cover and drill or punch a 7/8" hole (1/2" knockout). Insert the 7/8" bushing into the hole. Push the plastic tube through the bushing. Disconnect the leads from the LPTS housing and route the leads down the plastic tube. Reconnect the leads to the housing, observing the proper polarity (Red/Black or Red lead w/connector to positive (+) tab). Push the entire assembly back into the tube until the lens collar rests against the plastic tube. The plastic tube should be adjusted so that the LPTS is within 1/4" of the fixture lens. The LPTS must be visible after installation. Refer to *Illustration 1*.

Strip Fixture – Select a convenient location on the side of the fixture so the LPTS can be seen after installation. Allow for proper clearance inside the fixture and drill or punch a 1/2" hole. Disconnect the leads from the LPTS housing. Push the LPTS housing into the 1/2" hole until it is firmly locked in place. Reconnect the leads, observing the proper polarity (Red/Black or Red lead w/connector to positive (+) tab). Refer to *Illustration 2*.

Illustration 1 Recessed Troffer Fixture

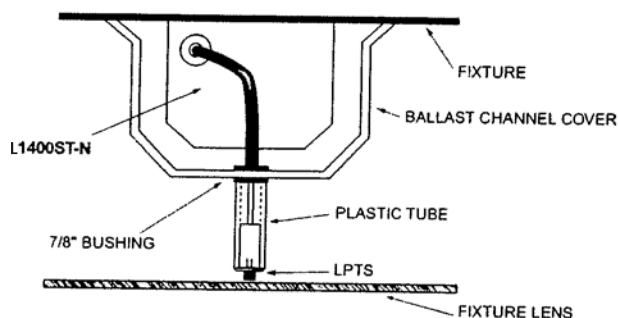
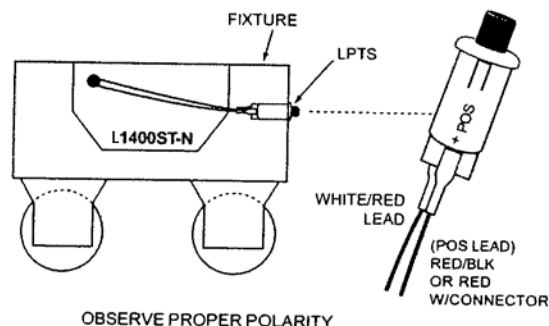

Illustration 2 Strip Fixture



5. WIRING THE A.C. INPUT

- A. The **L1400ST-N** and A.C. ballast **must** be on the same branch circuit.
- B. The **L1400ST-N** requires an **unswitched** A.C. power source of 110-277V 50/60HZ.
- C. When the **L1400ST-N** is used with a switched fixture, the A.C. input to the **L1400ST-N** must be connected ahead of the fixture switch. Refer to *Illustration 3* for switched and unswitched fixture wiring diagrams.

Illustration 3

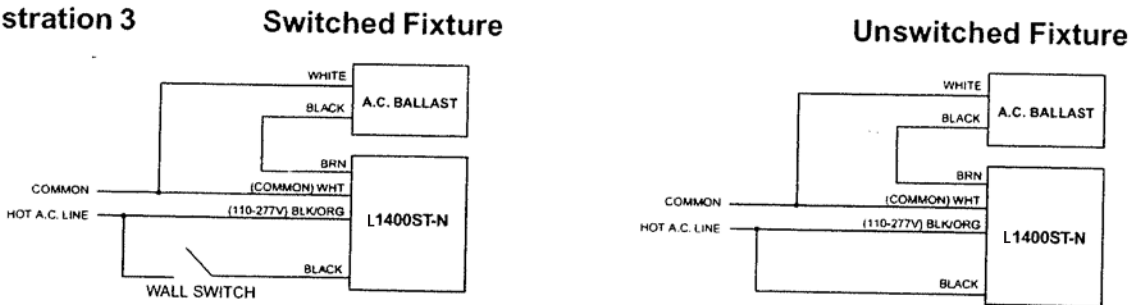

6. LABELS

Attach the appropriate labels adjacent to the **LPTS**. Annotate Re-lamping label for lamp type and wattage. The Caution and the Re-lamping labels must be on the fixture in a readily visible location to anyone attempting to service the fixture.

7. COMPLETING INSTALLATION

When the installation is complete, switch the A.C. power on and join the **L1400ST-N** unit connector.

OPERATION

Normal Mode – A.C. power is present. The A.C. ballast operates the fluorescent lamp(s) as intended. The **L1400ST-N** is in the standby charging mode. The **LPTS** will be lit (green) providing a visual indication that the battery is fully charged or (red) indicating that the battery is currently charging.

Emergency Mode – The A.C. power fails. The **L1400ST-N** senses the A.C. power failure and automatically switches to the *Emergency Mode*. One or two lamps are illuminated, at reduced output, for a minimum of 90 minutes. When the A.C. power is restored, the **L1400ST-N** switches the system back to the *Normal Mode* and resumes battery charging. See page 1 of the Instruction Manual.

TESTING & MAINTENANCE

Pressing the red lens on the **LPTS** turns off the light on the **LPTS** and forces the unit into emergency mode, interrupting power to the designated A.C. ballast. The emergency lamp is now being lit by the **L1400ST-N** unit. After releasing the **LPTS**, the fixture returns to normal operation after a momentary delay. To simulate a "BLACK OUT" use the circuit breaker to turn off A.C. power.

Initial Testing – Allow the unit to charge approximately 1 hour, then conduct a short discharge test. Allow a 72 hour charge before conducting a one hour test.

The **L1400ST-N** is designed to automatically conduct both 30-second and 90 minute tests at regular intervals every 26 to 28 days. Automatic Testing is outlined in the following schedule:

Automatic Monthly Testing – The **L1400ST-N** will automatically conduct a 30-second test once. If the **L1400ST-N** encounters a problem, the **LPTS** will flash and the internal beeper will sound. See Table below for diagnosis.

Automatic Annual Testing – The **L1400ST-N** will automatically conduct a 90 minute test every twelve months. If the **L1400ST-N** encounters a problem, the **LPTS** will flash and the internal beeper will sound. See Table below for diagnosis.

To insure accurate testing, the **L1400ST-N** will not conduct any scheduled automatic tests for a period of 72 hours after the unit has discharged, regardless of reason, for more than five minutes.

Manual Testing - Manual Testing can be performed on the **L1400ST-N** at any time, provided the unit is fully charged, by pressing the **LPTS**. Manual Testing will not interfere with the automatic testing schedule of the **L1400ST-N** and will display the same diagnosis indicators as automatic testing.

LED IS RED WHEN CHARGING, GREEN WHEN READY			FAILURE CODES OCCUR ONCE EVERY 15 SECONDS WITH 1 SECOND DELAY BETWEEN CODES IN INSTANCES OF MULTIPLE FAILURE
CHARGE FAILURE	1 BEEP	1 FLASH	
BATTERY FAILURE	2 BEEPS	2 FLASHES	
LAMP FAILURE*	3 BEEPS	3 FLASHES	
INVERTER FAILURE*	4 BEEPS	4 FLASHES	

*IF FAILURE, REPLACE LAMP AND RETEST

SERVICING SHOULD BE PERFORMED BY QUALIFIED PERSONNEL.

Consult Customer Service for current warranty information.

