



Unison Unit Equipment

6 and 12 Volt

18 to 72 Watt

Service Questions Call: 910-259-1000



OPERATING INSTRUCTIONS

IMPORTANT SAFEGUARDS

When using electrical equipment, basic safety precautions should always be followed, including the following:

READ AND FOLLOW ALL SAFETY INSTRUCTIONS

All servicing should be performed by qualified personnel only.

Equipment should be mounted in locations and at heights where it will not be readily subjected to tampering by unauthorized personnel.

The use of accessory equipment not recommended by the manufacturer may cause an unsafe condition.

Do not use this equipment for other than intended use.

Do not let supply cords touch hot surfaces.

Do not mount near gas or electric heaters.

Caution: Halogen cycle lamp(s) are used in this equipment. To avoid shattering: Do not operate lamp in excess of rated voltage, protect lamp against abrasion and scratches and against liquids when lamp is operating, dispose of lamp with care.

Halogen cycle lamps operate at high temperatures. Do not store or place flammable materials near lamp.

Use caution when servicing batteries. Battery acid can cause burns to skin and eyes. If acid is spilled on skin or eyes, flush acid with fresh water and contact a physician immediately.

CAUTION: To avoid electrical overload, total connected lamp load (factory and field installed) should not exceed output rating.

SAVE THESE INSTRUCTIONS

WARNING – Shut off AC power to branch circuits to which units will be connected. All wiring should be per N.E.C. Articles 501-4(b) and local codes.

To maintain warranty, equipment with batteries must be installed or placed on charge within prescribed period after shipment.

GENERAL INSTRUCTIONS

Figure 1

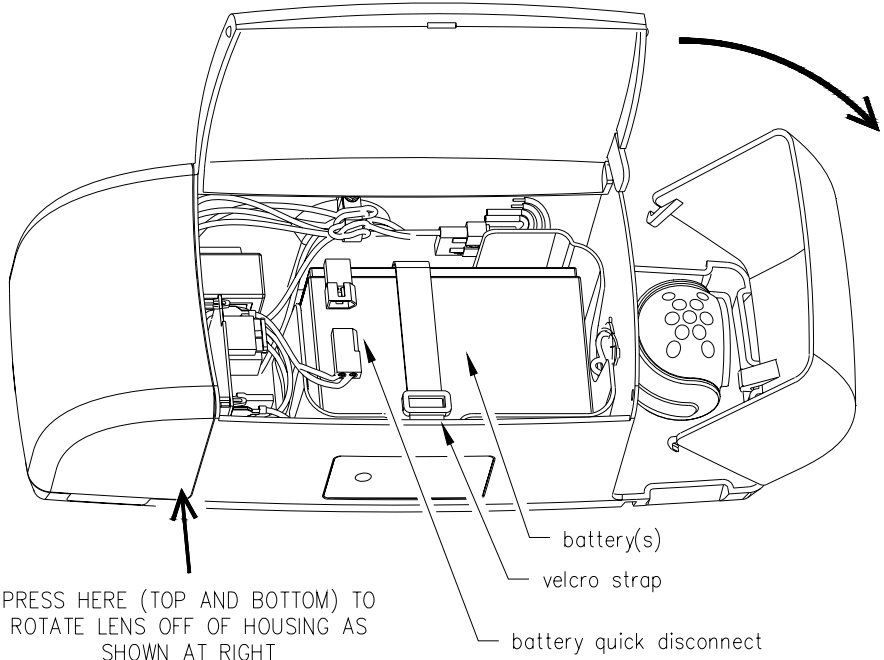

STEP 1 (see figure 1)

Expose junction box mounting pattern by loosening velcro strap over battery or batteries and removing them from the housing (leave velcro strap in the housing). A quick disconnect is provided between the electronics and batteries. Be certain that this quick disconnect is disconnected before attempting to remove batteries. If it is planned to use toggle bolts to mount unit to wall, additional knockouts intended for this purpose can be found under the lenses. These keyhole slots will accommodate #6 toggle bolts. Refer to the sketch above for instructions on removing the lenses.

Figure 2

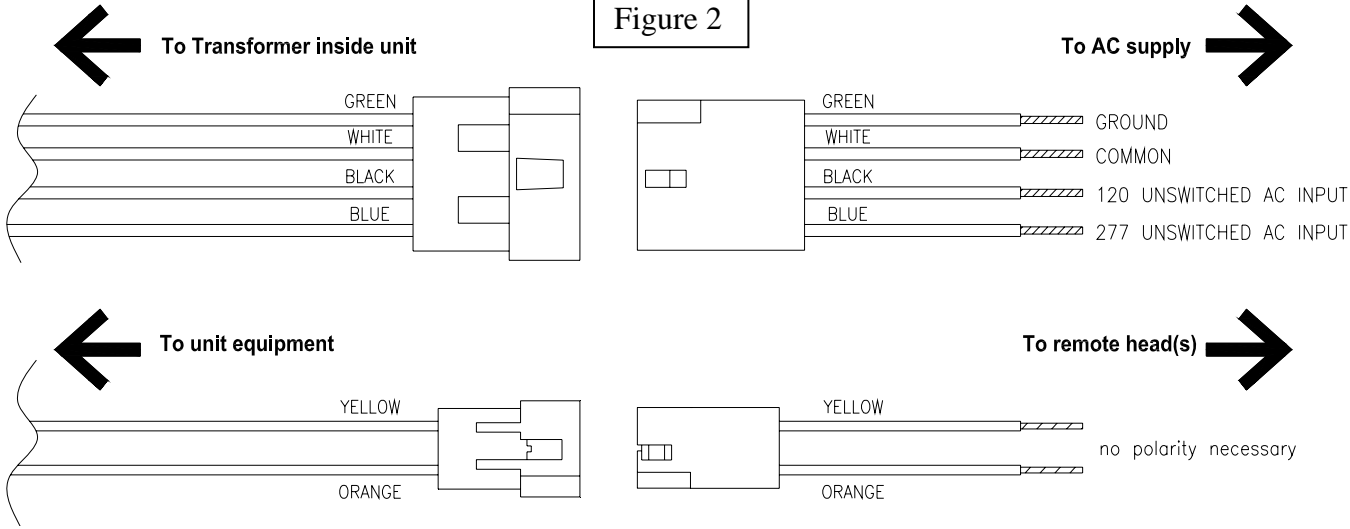

STEP 2 (see figure 2)

Locate 4 pole connector attached to transformer inside unit. Remove 6" long extension cable and wire to AC supply as shown. Unused black or blue lead must be insulated to prevent shorting. If your unit has battery capacity in excess of the wattage required by its internal lamp heads, it will be provided with a 2 pole remote lamp connector as well. Remote lamp heads used must match voltage of unit (6 or 12 volt) and the combined wattage of the internal and remote lamp heads must not exceed the rated wattage of the equipment – refer to nameplate label for maximum wattage. If unit is not used to power any remote heads, be certain to insulate the unused orange and yellow leads to prevent shorting or discard the 6" orange/yellow extension cable.

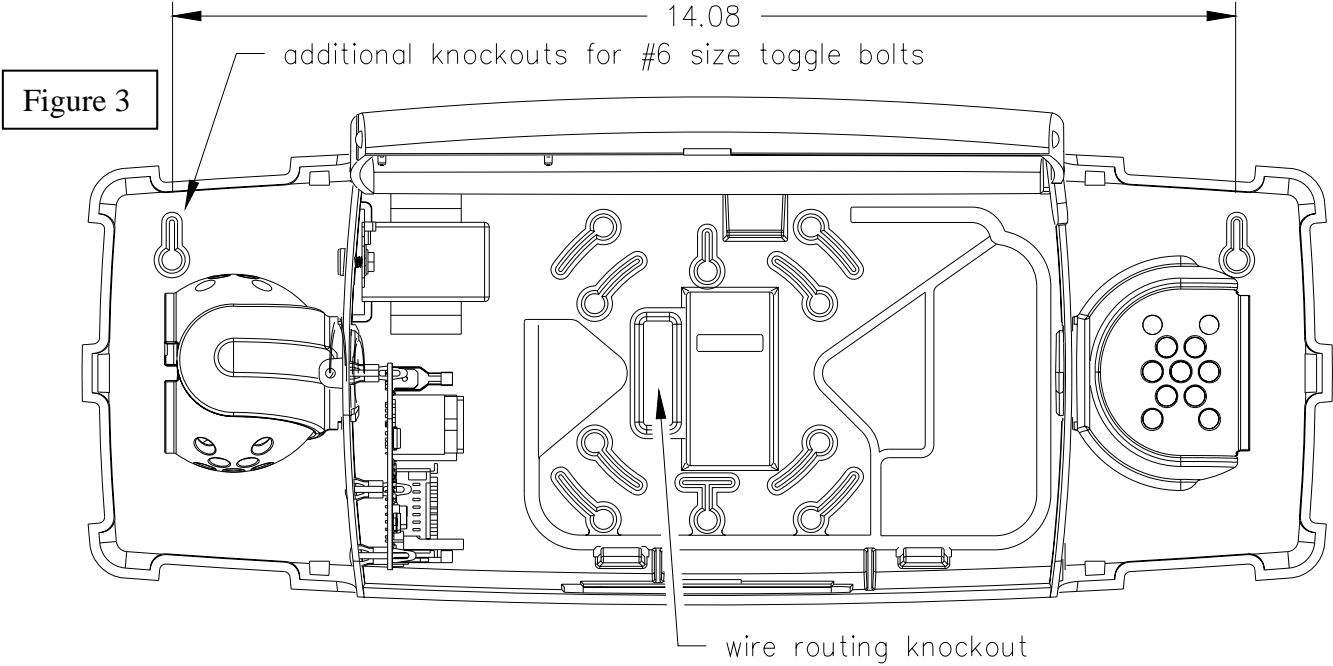

STEP 3 (see figure 3)

Remove desired knockouts for junction box or toggle bolt mounting. Also remove the larger rectangular knockout for routing of AC leads unless using the conduit knockout found on top of the housing. Mount unit to wall or ceiling using fasteners supplied with junction box or mount to wall using toggle bolts (not provided). Pull AC and remote lamp connectors through rectangular knockout and reconnect to matching wire harnesses as shown in step two. Reinstall the battery and connect the battery quick disconnect. Re-secure the Velcro battery strap to secure the battery in place. Energize AC supply branch circuit and refer to page 5 for operating instructions.

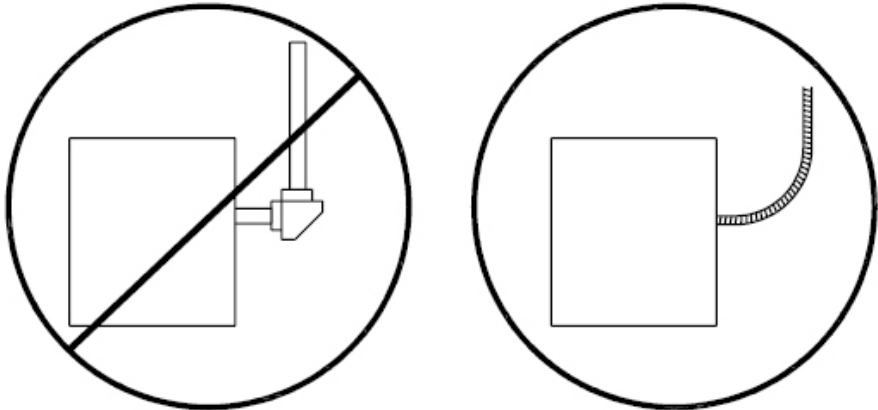

No rigid conduit – Flexible conduit only

MAINTENANCE

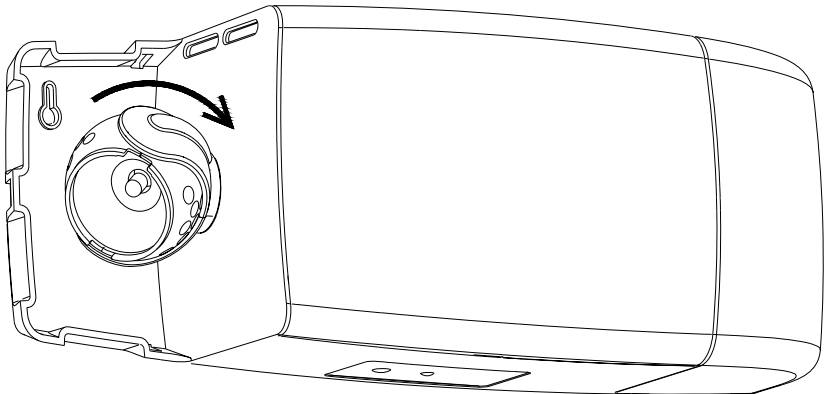

LAMP HEAD AIMING – Remove lens covers as shown in step 1. Lamp heads may be aimed by grasping them at the base and rotating them to aim at the desired location. Lamp head only rotates approximately 135° which is enough to aim in any direction whether mounted on wall or ceiling.

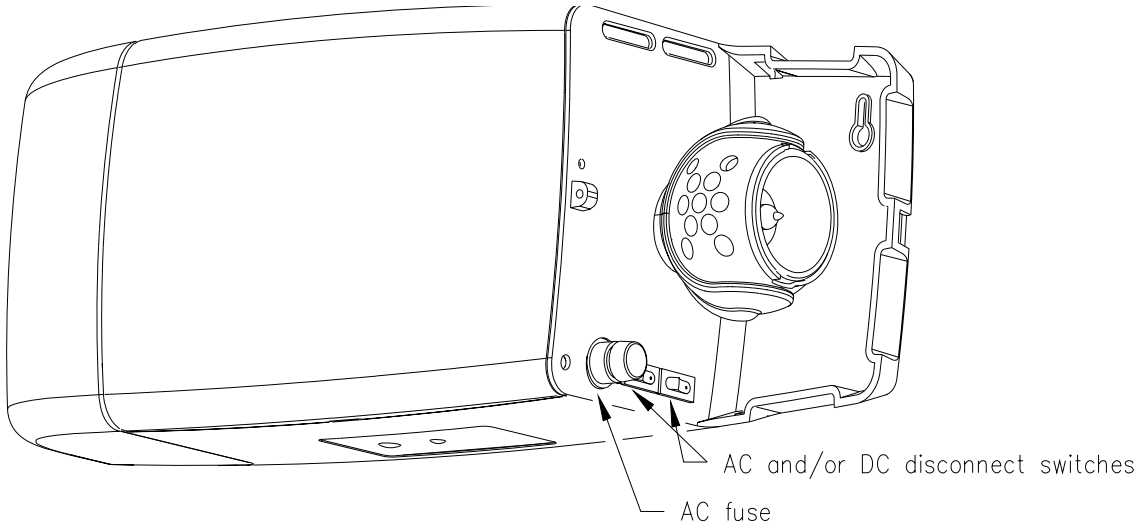

AC FUSE AND AC OR DC DISCONNECT SWITCH OPTIONS – If ordered, these options can be found under the right lamp head lens.

PAN HEAD SCREW.
DRIVE THRU SIDE OF
HOUSING
INTO CLOSED DOOR
(ONE SCREW FOR
EACH SIDE OF UNIT)

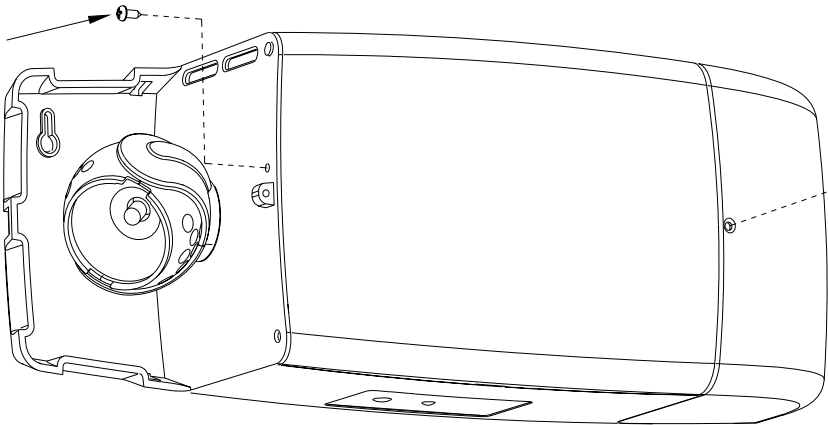

FLAT HEAD SCREW.
DRIVE THRU LENS INTO
BOSS FOUND ON
HOUSING (ONE SCREW
FOR EACH SIDE OF
HOUSING)

TAMPERPROOFING – If ordered, install this option using the included screw kit which includes two flat head screws, two pan head screws and a tamperproof Torx T-15 bit.

SELF DIAGNOSTICS SYSTEM OPERATION

Normal Power-Up Sequence

At power-up, the red and green LED indicators will alternately flash for one to two seconds. Next, the unit will go through a “Power-Up Quick Test” with the green LED flashing quickly. If no power-up faults were detected, the green LED will then flash slowly for up to 36 hours to indicate that the battery is charging. If any faults were detected during the “Power-Up Quick Test”, these will be indicated by a flashing red LED indicator (see below for interpretation of flashing sequences). The red LED may be accompanied by a buzzer if audible diagnostics were ordered. This buzzer may be disabled by a short press of the test switch or by the “SILENCE ALARM” button on the remote tester and will remain disabled for a period of 196 hours. After the fault has been corrected, the red LED flash and buzzer will be cleared automatically and the unit will return to normal operation.

Emergency Operation

Emergency operation occurs when AC power fails. The unit remains in this mode until AC power is restored. During emergency operation, both red and green LED indicators are disabled. Upon restoration of AC power, the green LED will flash for up to 36 hours to indicate that the unit is in battery charging mode.

User Interface

Green LED Indicator

- Steady On – AC power is present and battery is fully charged
- Slow Flash – Battery charging
- Fast Flash – Unit is performing an automatic or manually initiated self-test

Red LED Indicator

- Single Flash – Battery fault
- Double Flash – Lamp failure
- Triple Flash – Charger fault
- Quad Flash – Transfer fault

(If more than one fault condition is present simultaneously, the red LED will flash each fault pattern in sequence, then repeat)

Red and Green LED Indicators flashing in an alternating sequence

- Fast flashing red and green with audible tone – 277VAC applied to 120VAC input lead. **REMOVE POWER IMMEDIATELY!**

Pushbutton Test Switch

- Long Press (over .5 seconds) – Transfers unit to emergency (battery) operation as long as button is depressed
- Short Press – Initiates various self tests
 - One Press – Cancel and self-test currently running
 - Two Presses – Start 1 minute self-test
 - Three Presses – Start 90 minute self-test
 - Seven presses – Forces a complete system reset

(The unit will allow up to seven 1 minute tests during the first 24 hours of operation. Allow at least 24 hours for battery charging before performing and extended amount of testing)

Buzzer (Option) – Sounds in unison with the flashing red LED if a fault is detected. May be disabled for up to 196 hours by a short press of the test switch (or by pressing the “SILENCE ALARM” button on the remote tester).

IR Receiver – Used with the optional hand-held IR remote tester. (order part number ICIR) to initiate or cancel manual testing.