



# EMERGENCY FLUORESCENT LIGHTING BALLAST

## INSTALLATION AND OPERATING INSTRUCTIONS

### IMPORTANT SAFEGUARDS

When using electrical equipment, basic safety precautions should always be followed, including the following:

### READ AND FOLLOW ALL SAFETY INSTRUCTIONS

All servicing should be performed by qualified personnel only.

To prevent high voltage from being on red & yellow output leads prior to installation, battery connector must be open. Do not join battery connector until installation is complete and AC power is supplied to the emergency ballast. Do not use this equipment outdoors.

This product is designed for use in UL Listed indoor fixtures except in air handling, heated air outlet or hazardous locations.

Do not let power supply cords touch hot surfaces.

Do not mount near gas or electric heaters.

Do not mount near open flames or sparks.

Do not use this equipment for other than intended use.

Do not attempt to service battery. Contact manufacturer for information on service.

This product is suitable for use in Damp Locations  
Temperature Range: 0°C To 55°C.

This product is for use with most 17W through 215W (2'-8') single pin or bipin fluorescent lamps, including standard, energy saving, HO, VOH, circline, U-shaped, rapid-start 4-pin long compact 18W-55W and 4-pin 18W-32W compact lamps without integral starters.

An unswitched AC power source is required (120 or 277 VAC).

The use of accessory equipment not recommended by the manufacturer may cause an unsafe condition.

This emergency ballast is for factory or field installation in either the ballast channel or on top of the fixture.

To reduce the risk of electrical shock, disconnect both normal and emergency power supplies before servicing by disconnecting all AC inputs to the fixture and by disconnecting the battery.

### SAVE THESE INSTRUCTIONS

### INSTALLATION INSTRUCTIONS

#### WARNING

To prevent high voltage from being present on red & yellow output leads prior to installation, battery connector must be open. Do not join battery connector until installation is complete and AC power is supplied to the emergency ballast.

#### NOTE:

Make sure that the necessary branch circuit wiring is available. An unswitched source of power is required. The emergency ballast must be fed from the same branch circuit as the AC ballast.

1. Disconnect AC power from the fixture. Remove the ballast channel cover and install the emergency ballast either on top of the fixture (See illustration 1) or in the ballast channel (See illustrations 2 and 3).
2. Select the appropriate wiring diagram to connect the emergency ballast to the AC ballast and lamp. Make sure all connections are in accordance with the National Electrical Code and any local regulations.

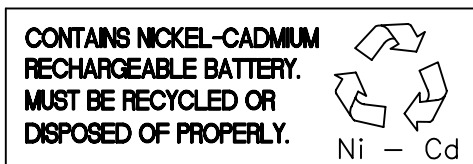
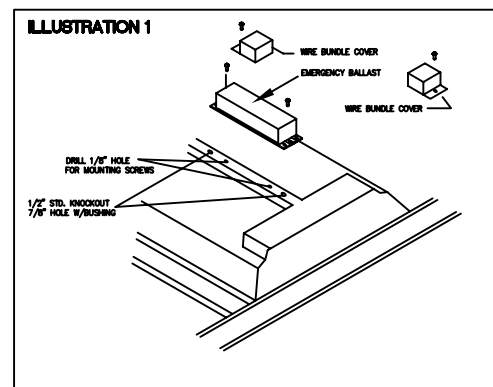

# L1400DL EMERGENCY FLUORESCENT LIGHTING BALLAST

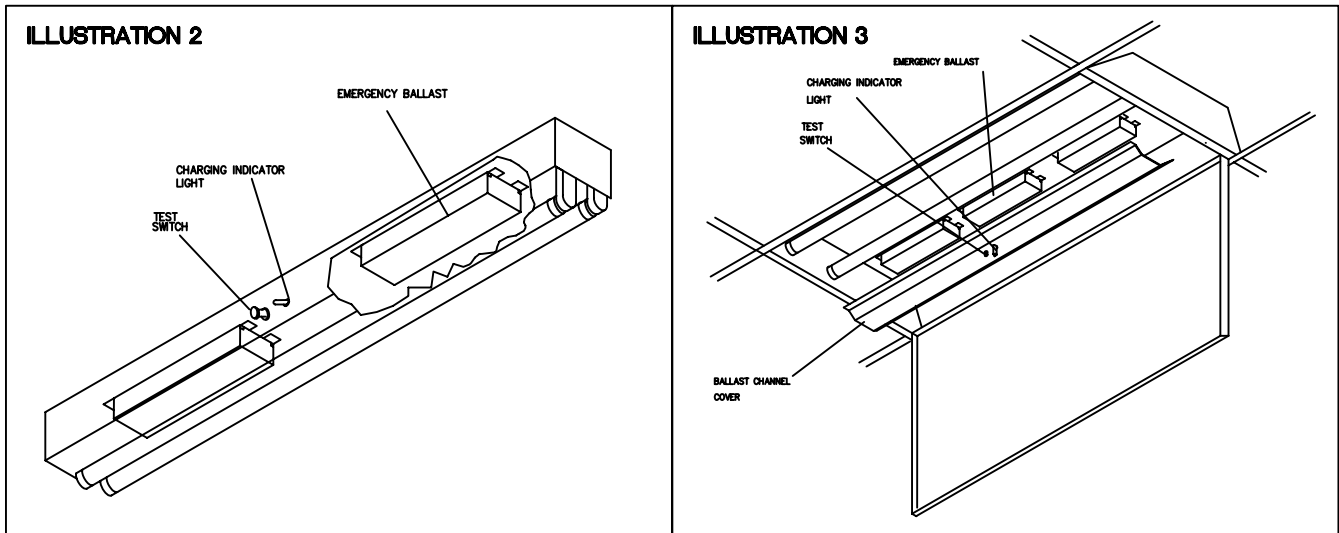

3. Install the test switch through the ballast channel cover of a troffer or through the side of a strip fixture. Drill a 1/2" hole and install the switch as shown (See illustrations 2, 3 and 4). Wire the test switch so that it removes AC power from both the emergency ballast and the AC ballast at the same time (See illustration 6).

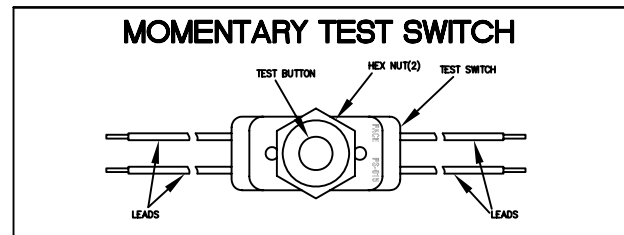
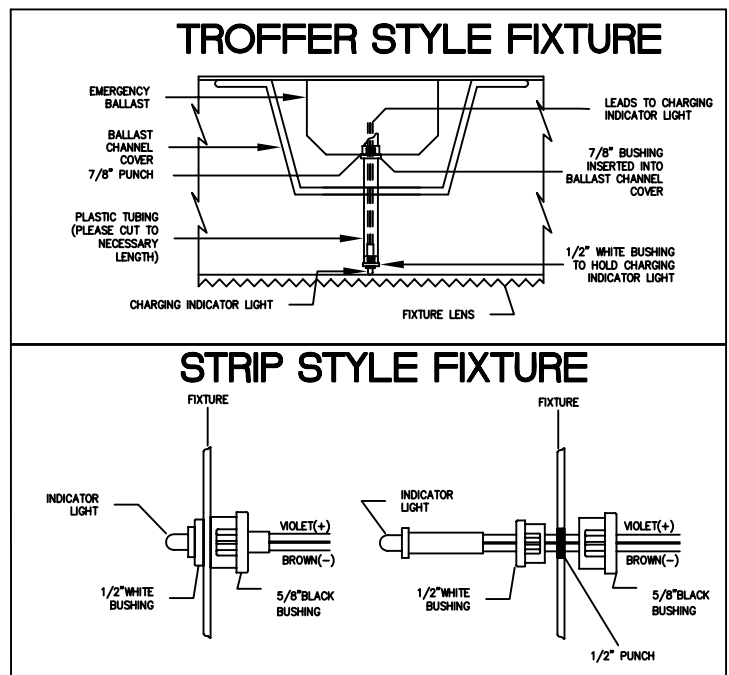

**ILLUSTRATION 4**

4. Refer to illustration 5 and install the charging indicator light so that it will be visible after the fixture is installed.

**NOTE:**

After installing the charging indicator light and test switch, mark each with the appropriate label. If a detached charging indicator light is used, connect by matching wire colors and install as shown in illustration 5.



**ILLUSTRATION 5**

5. In a readily visible location, attach the label "Caution - This Unit Has More Than One Power Connection Point. To Reduce The Risk Of Electric Shock, Disconnect Both The Branch Circuit Or Fuses And Emergency Power Supplies Before Servicing."

# L1400DL EMERGENCY FLUORESCENT LIGHTING BALLAST

## TEST SWITCH WIRING DIAGRAMS

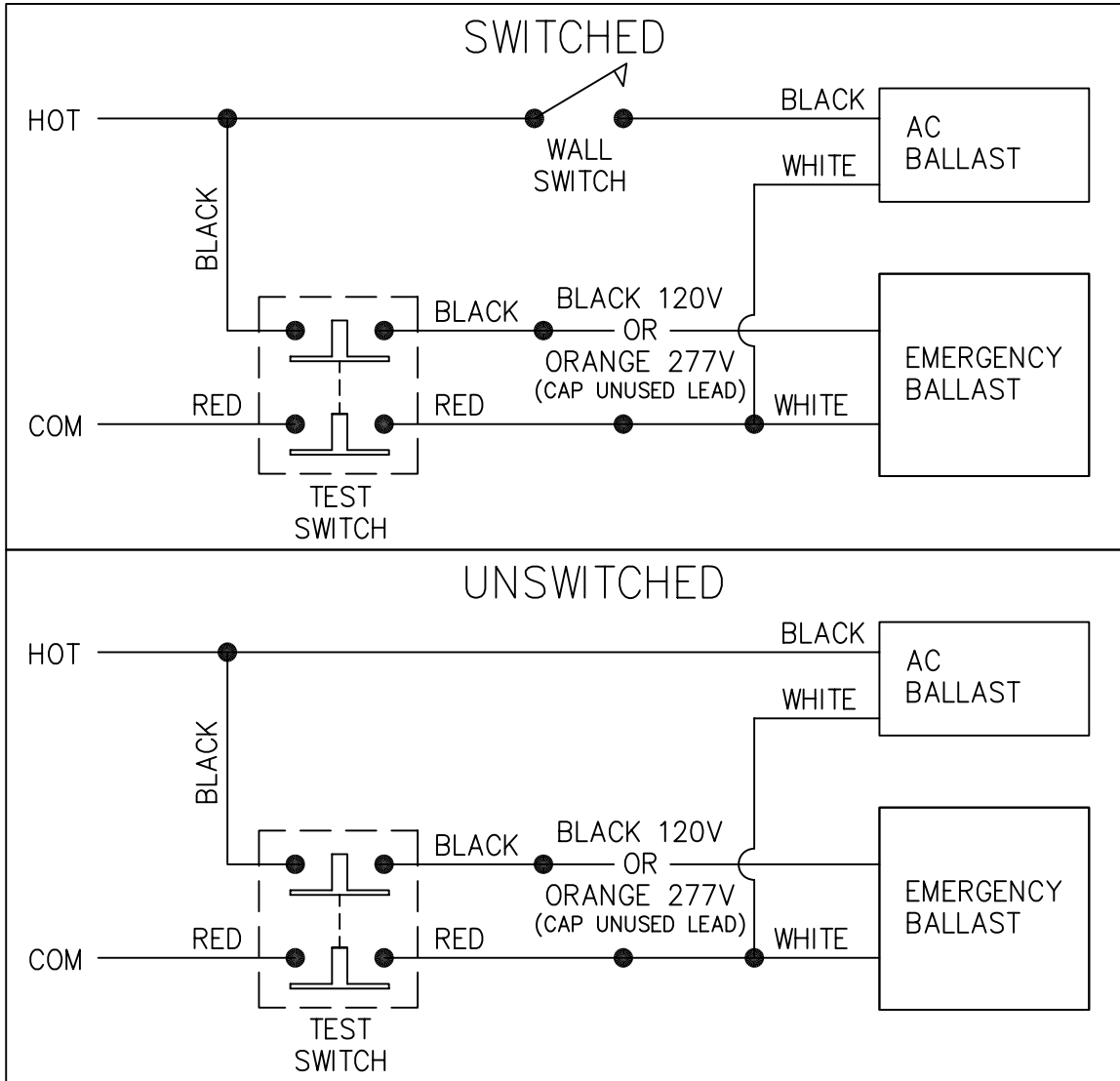

ILLUSTRATION 6

**NOTE:** After installing the charging indicator light and test switch, mark each with appropriate label.

6. After installation is complete, supply AC power to the emergency ballast and join the battery connector.
7. A short-term discharge test may be conducted after the emergency ballast has been charging for one hour. Charge for 24 hours before conducting a long-term discharge test. Refer to OPERATION.

## OPERATION

When AC power is applied, the charging indicator light is illuminated, indicating that the battery is being charged. When power fails, the emergency ballast automatically switches to emergency power, operating either one or two lamps at reduced illumination for at least 90 minutes.

## MAINTENANCE

Although no routine maintenance is required to keep the emergency ballast functional, it should be checked periodically to ensure that it is working. The following schedule is recommended:

1. Visually inspect the charging indicator light monthly. It should be illuminated.
2. Test the emergency operation of the fixture at 30-day intervals for a minimum of 30 seconds. Either one or two lamps should operate at reduced illumination.
3. Conduct a 90-minute discharge test once a year. either one or two lamps should operate at reduced illumination for at least 90-minutes.

# L1400DL EMERGENCY FLUORESCENT LIGHTING BALLAST

## WIRING DIAGRAMS

The following diagrams are typical schematics only.  
 This unit may be used with other ballast. Consult Factory for other  
 wiring diagrams. Emergency Ballast and AC Ballast must  
 be fed from the SAME BRANCH CIRCUIT.

TABLE 1				
LAMP DIA.	BASE TYPE	POWER (LENGTH)	NUMBER OF LAMPS EMER.	BROWN CONNECTOR
1", 1-1/4", 1-1/2" (T8,T10,T12)	SINGLE OR BIPIN	17-24 W (2'-4')	1	CLOSED
			2	OPEN
1", 1-1/4", 1-1/2" (T8,T10,T12)	SINGLE OR BIPIN	32-40 W (2'-4')	1	CLOSED
			2	OPEN
		40-215 W (5'-8')	1	OPEN
LONG COMPACT	4 PIN (2G11)	18-39 W	1	CLOSED
			2	OPEN
		40-55 W	1	OPEN
COMPACT	4 PIN (G24q,GX24q)	18-32 W	1	CLOSED
			2	OPEN

### ONE OR TWO LAMP EMERGENCY OPERATION

#### A. ONE (1) LAMP RAPID START BALLAST

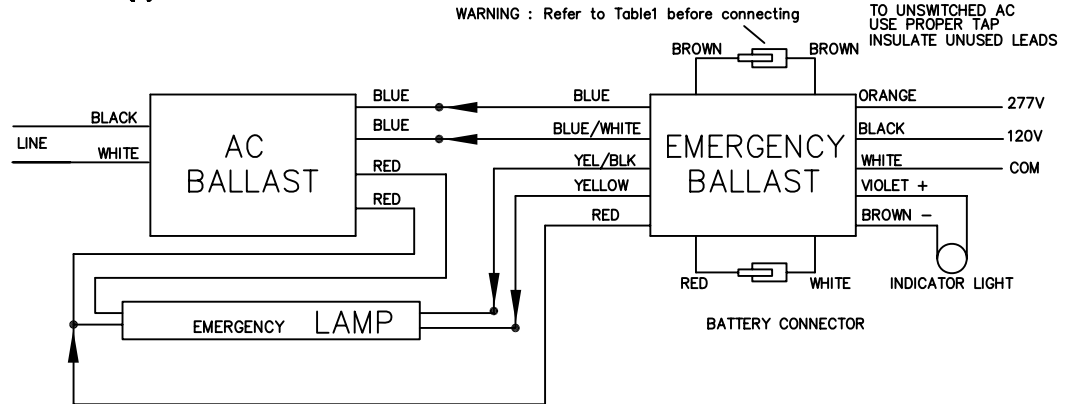

#### B. TWO (2) LAMP RAPID START BALLAST

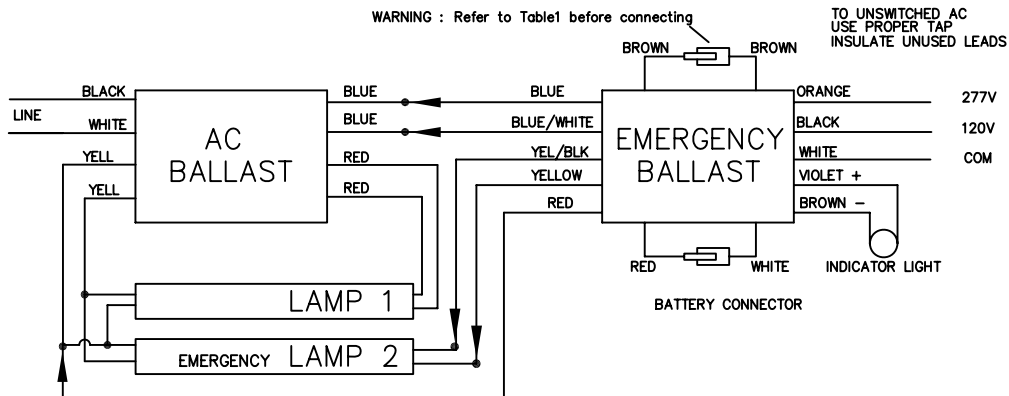

# L1400DL EMERGENCY FLUORESCENT LIGHTING BALLAST

## WIRING DIAGRAMS

### C. ONE (1) LAMP INSTANT START SLIMLINE BALLAST

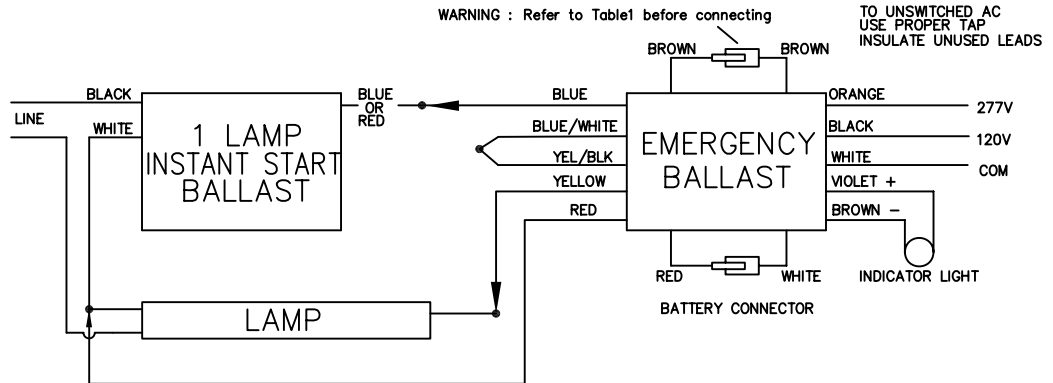

### D. TWO (2) LAMP INSTANT START SLIMLINE BALLAST

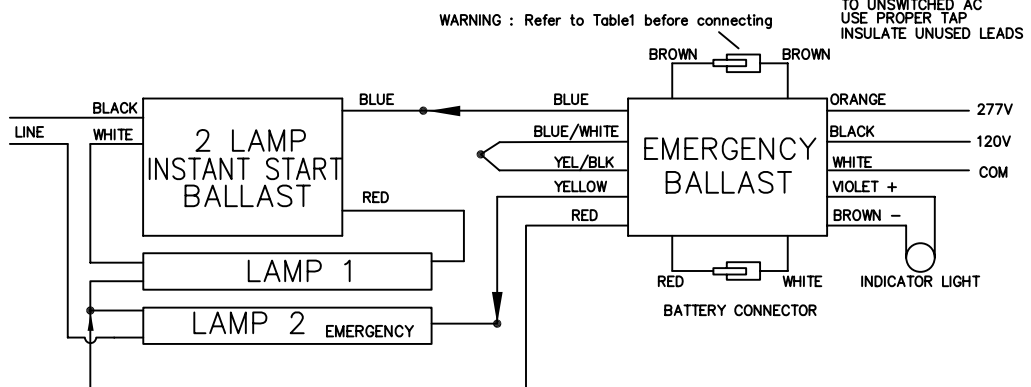

### E. TWO (2) LAMP SERIES SEQUENCE INSTANT START BALLAST WITH FOUR (4) LEADS

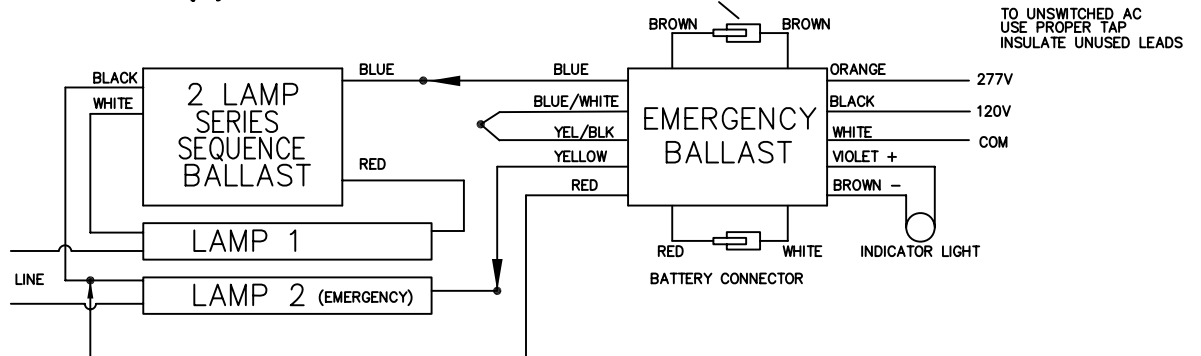

# L1400DL EMERGENCY FLUORESCENT LIGHTING BALLAST

## WIRING DIAGRAMS

### F. TWO (2) LAMP INSTANT START ELECTRONIC BALLAST

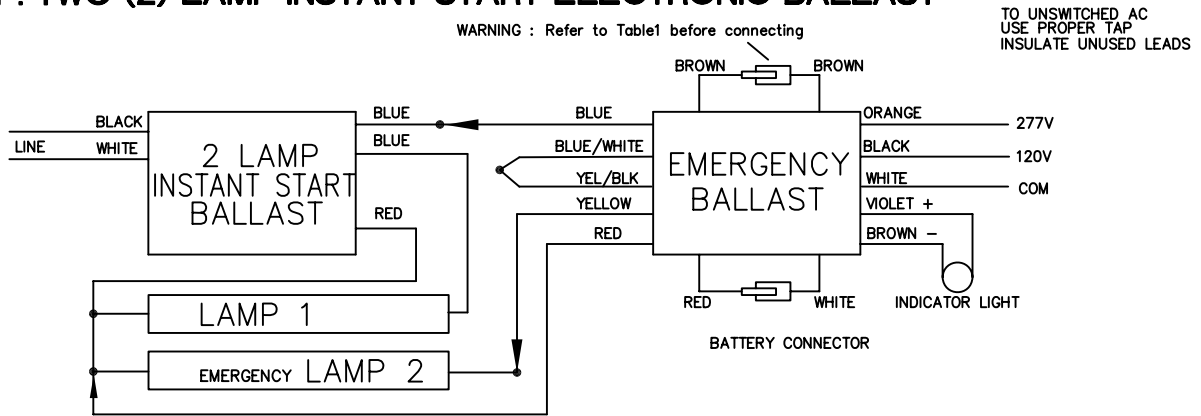

### G. THREE LAMP RAPID START ELECTRONIC BALLAST

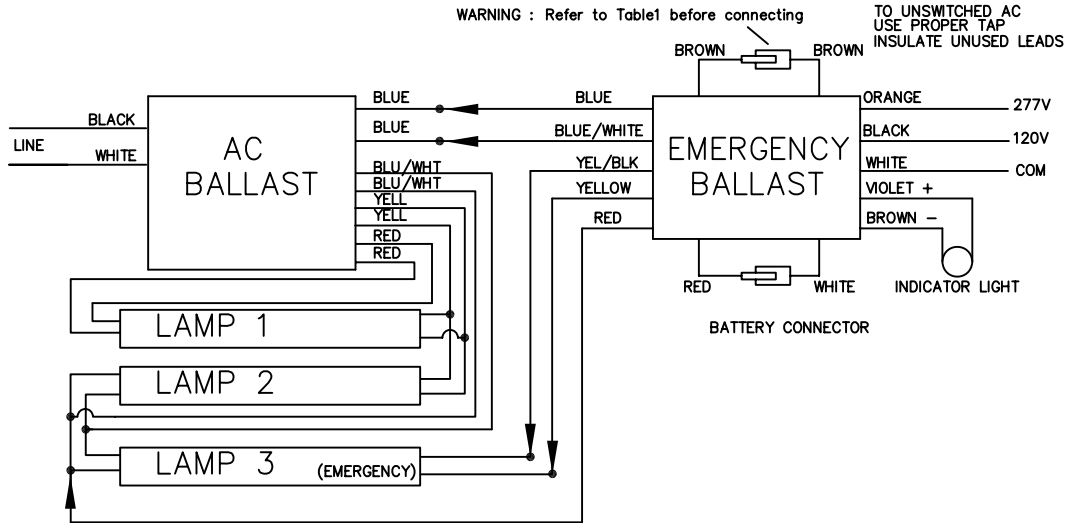

### H. THREE (3) LAMP INSTANT START ELECTRIC BALLAST

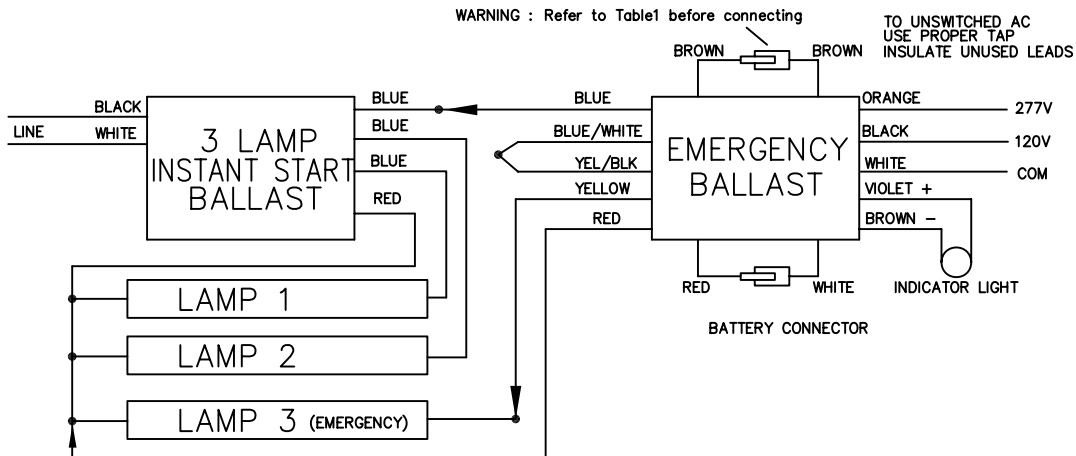

# L1400DL EMERGENCY FLUORESCENT LIGHTING BALLAST

## I. FOUR (4) LAMP INSTANT START ELECTRONIC BALLAST

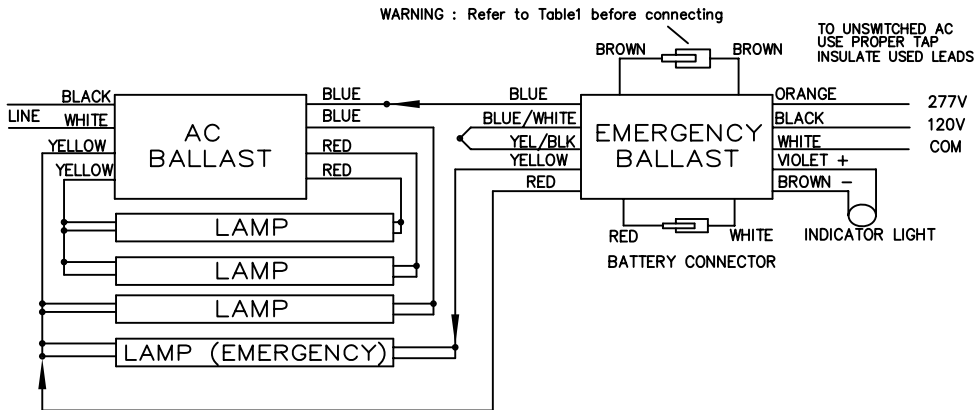

## WIRING DIAGRAMS- TWO LAMP- EMERGENCY OPERATION

### J. TWO (2) LAMP LEAD/LAG INSTANT START SLIMLINE BALLAST

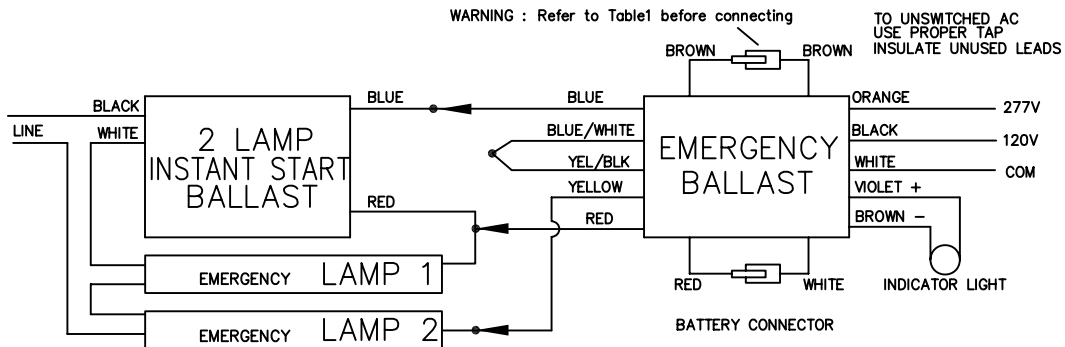

### K. TWO (2) LAMP RAPID START BALLAST

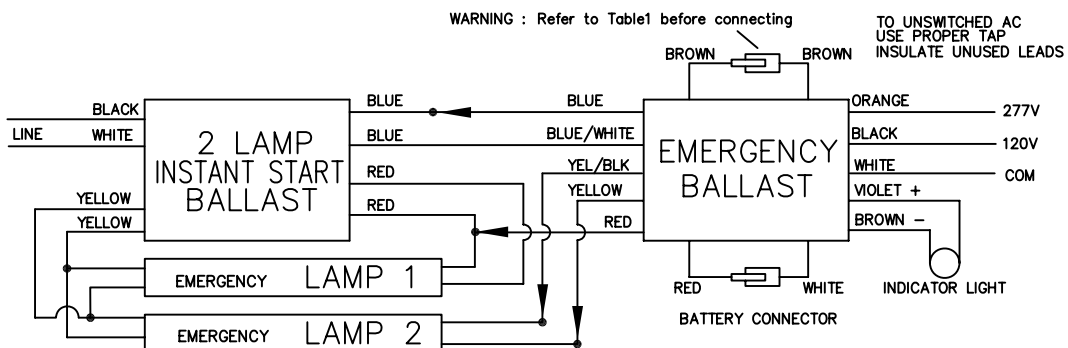

# L1400DL EMERGENCY FLUORESCENT LIGHTING BALLAST

## L. FOUR (4) LAMP INSTANT START ELECTRONIC BALLAST

WARNING : Refer to Table1 before connecting

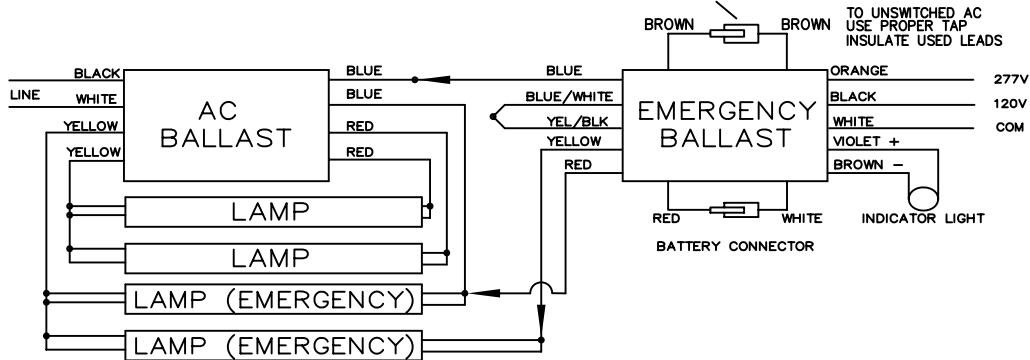

## WIRING DIAGRAMS- EMERGENCY-ONLY - FIXTURES

### M. ONE (1) WITHOUT AC BALLAST

WARNING : Refer to Table 1 before connecting

TO UNSWITCHED AC  
USE PROPER TAP  
INSULATE UNUSED LEADS

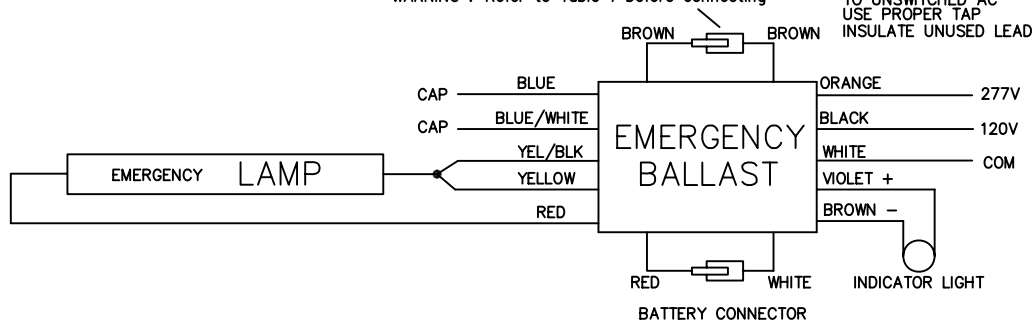

### N. TWO (2) LAMPS WITHOUT AC BALLAST

WARNING : Refer to Table1 before connecting

TO UNSWITCHED AC  
USE PROPER TAP  
INSULATE UNUSED LEADS

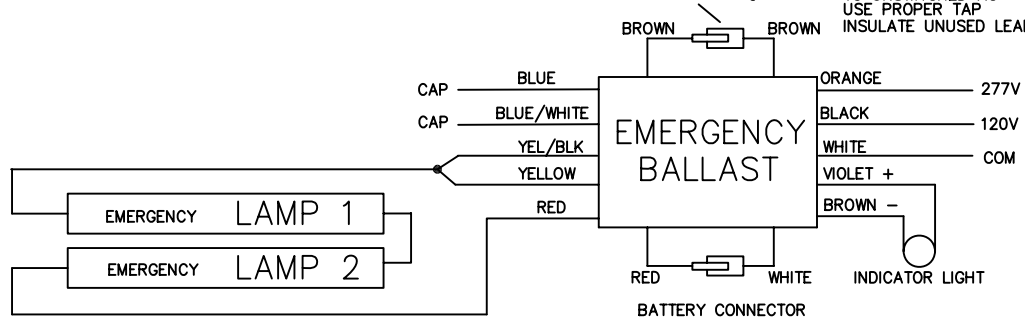

For diagrams not shown,  
please call the factory with Ac ballast  
brand name and catalog number.