



L1400T

Service Questions Call: 910-259-1000

IMPORTANT SAFEGUARDS

When using electrical equipment, basic safety precautions should always be followed, including the following:

READ AND FOLLOW ALL SAFETY INSTRUCTIONS

All servicing should be performed by qualified personnel only.

To prevent Electrical shock, do not connect emergency ballast battery connectors until installation is complete and AC power has been applied.

This product is designed for use in UL listed indoor fixtures only, except for those used in air handling, heated or hazardous locations.

Equipment should be mounted in locations and at heights where it will not be readily subjected to tampering by unauthorized personnel.

Do not use this equipment for other than intended use.

Do not use outdoors.

Do not let supply cords touch hot surfaces.

Do not mount near gas or electric heaters.

Do not install in areas of excessive moisture.

Do not use this equipment for other than its intended use.

Do not attempt to service the battery. Contact manufacturer for information on servicing equipment.

Ensure all power has been removed prior to start of installation.

Install in accordance with National Electrical Code and local code guidelines.

SAVE THESE INSTRUCTIONS

PRODUCT DESCRIPTION

The L1400T Emergency ballast requires an unswitched 120V or 277V AC input and is designed for use with one 17-40W (2-4'), 40-215W (5-8'), single or bi-pin T8, T10 or T12; 28W T5, 54W T5HO; 18-55W 4-pin Long Compact 2G11, and 18-57W, 4-pin Compact G24Q and GX24Q lamps (refer to Table 1 for proper installation application). The L1400T provides a minimum of 90 minutes of emergency operation in accordance with UL924 requirements. A momentary test switch, charging indicator light are supplied with the L1400T.

The L1400T also has a Time Delay circuit that when used in conjunction with an AC ballast with EOL detection, helps prevent false over voltage and over current detection, by the AC ballast, during the transition from emergency to normal operating mode.

EMERGENCY LAMP OPERATION

LAMP TYPE	BASE TYPE	WATTAGE & LENGTH	EMERGENCY LAMPS	BROWN LEADS
T8, T10, T12	SINGLE or BI-PIN	17-40W; 2-4'	1	CLOSED
			2	OPEN
		40-215W; 5-8'	1	OPEN
LONG COMPACT	4PIN (2G11)	18-39W	1	CLOSED
			2	OPEN
		40-55W	1	OPEN
COMPACT	4PIN (G24Q,GX24Q)	18-32W	1	CLOSED
			2	OPEN
		42, 57W	1	OPEN
T5	BI-PIN	28W	1	OPEN
T5HO	BI-PIN	54W	1	OPEN

WARNING

**ENSURE ALL AC POWER HAS BEEN REMOVED FROM
FIXTURE BEFORE BEGINNING INSTALLATION**

INSTALLATION

CAUTION: TO PREVENT ELECTRICAL SHOCK, BATTERY CONNECTORS SHOULD NOT BE CONNECTED UNTIL INSTALLATION IS COMPLETE AND AC POWER HAS BEEN APPLIED TO EMERGENCY BALLAST.

1. Install the L1400T emergency ballast (see Illustration 1) on top of fixture or in ballast channel (see Illustrations 2 and 3). Wire bundle covers (item no. CCAPS) are sold separately.
2. Install momentary test switch through the side of the strip fixture (see Illustration 2) or through the ballast channel cover (see Illustration 3) by drilling a 1/2" mounting hole and securing with hex nuts. See wiring diagrams for proper connection of test switch

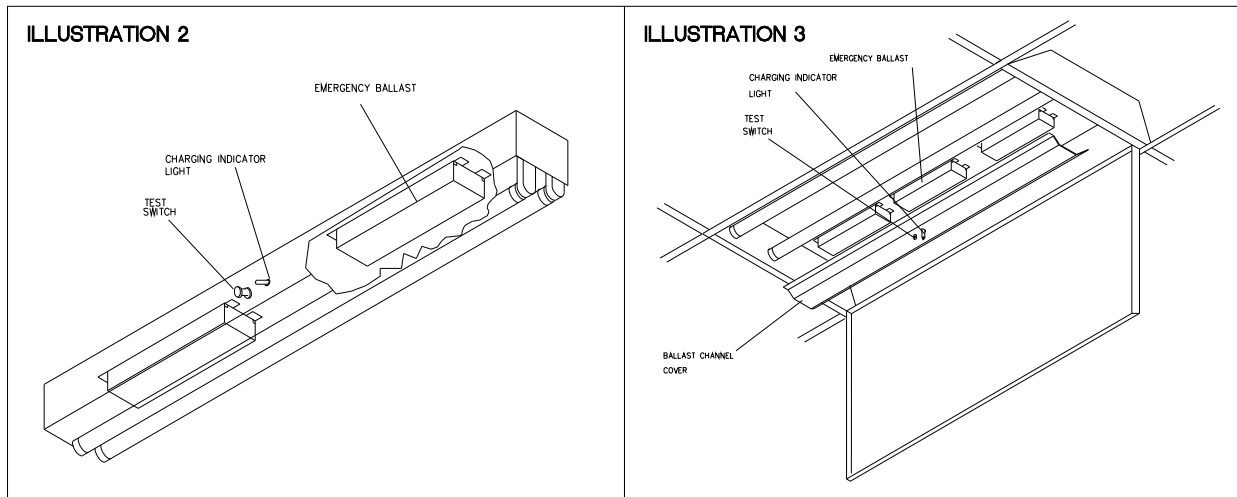
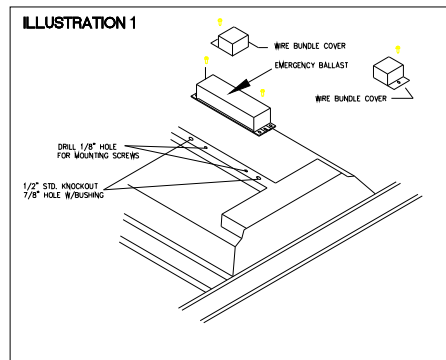
INSTALLATION CONT.

Caution: Test switch must be installed in line with an unswitched AC source as shown in wiring diagrams. If the L1400T is installed in a switched fixture, the fixture switch must be wired to only control the AC ballast for the fixture.

3. Install charge indicator light (see Illustration 4) by drilling appropriate size mounting hole and being careful to ensure that it will be visible after installation is complete.
4. Install labels supplied for the test switch and charging indicator light.
5. In a readily visible location, install the “Caution – This unit has more than one power connection point. To reduce the risk of shock, disconnect both the branch circuit breakers or fuses and emergency power supplies before servicing.”
6. Upon completion of installation, apply AC power to the L1400T emergency ballast and connect the battery connectors.
7. Ensure ballast channel cover and lamp guard or lens is installed, if required, and proceed to OPERATION section.

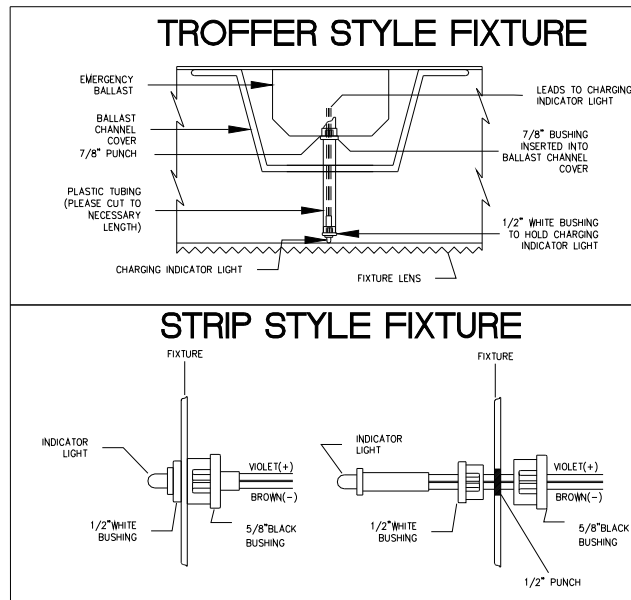
INSTALLATION CONT.**ILLUSTRATION 4****OPERATION**

1. After the AC power has been applied to the L1400T, verify the charging indicator is illuminated. If not, refer to wiring diagrams and recheck wiring.
2. Allow the L1400T battery to charge for one hour before performing any further testing. The L1400T should be allowed to charge for a minimum of 72 hours before a full discharge test is performed.
3. After the initial one hour charge, a short term discharge test may be performed by pressing and holding the momentary test switch.
4. Verify the lamp(s) is lit, based on the chosen configuration, at a reduced illumination level, while the switch remains pressed.
5. If the fixture is used for emergency operation only, release the test switch and the lamp(s) will go out. If the fixture is used for normal and emergency operation, upon release of the test switch, the lamp(s) will remain out for approximately 4 seconds before returning to normal illumination levels.
6. If a full discharge test is being performed, remove AC power and verify the lamp(s) is illuminated, at a reduced level, for a minimum of 90 minutes, in accordance with UL924.

Note: If the unit fails to operate properly, please consult the manufacturer.

MAINTENANCE

Although no routine maintenance is required for the L1400T, the following tests should be performed periodically to maintain compliance with national and local codes.

1. Monthly, visually check to see that the charging indicator is illuminated.
2. Test the L1400T emergency ballast operation (see OPERATION section) at 30 day intervals for a minimum of 30 seconds.
3. Once a year, conduct a 90 minute discharge test (see OPERATION section).

WIRING DIAGRAMS

The following are typical wiring diagrams. Emergency and AC ballast must be fed from the same branch circuit. Please consult the factory for wiring diagrams not shown

ONE LAMP EMERGENCY OPERATION

A. ONE (1) LAMP w/ RAPID START BALLAST

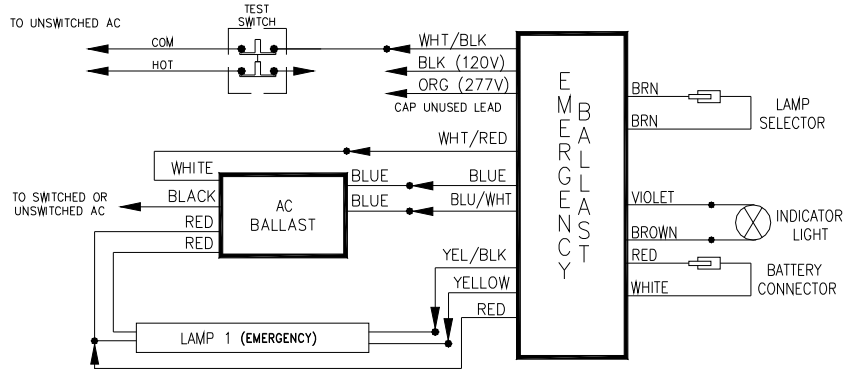

B. TWO (2) LAMP w/ RAPID START BALLAST

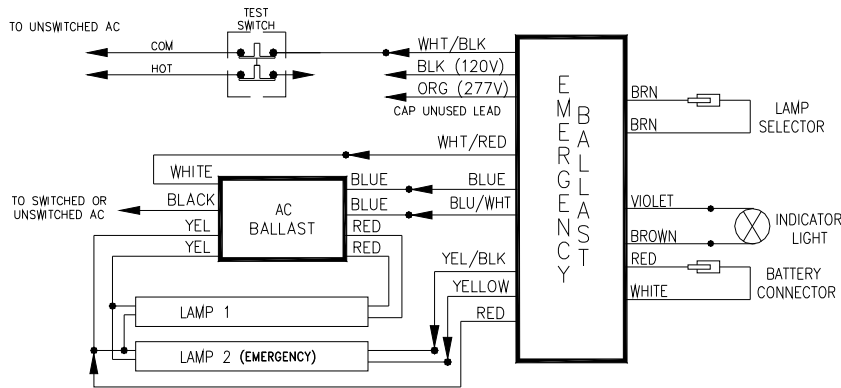

C. THREE (3) LAMP w/ RAPID START BALLAST

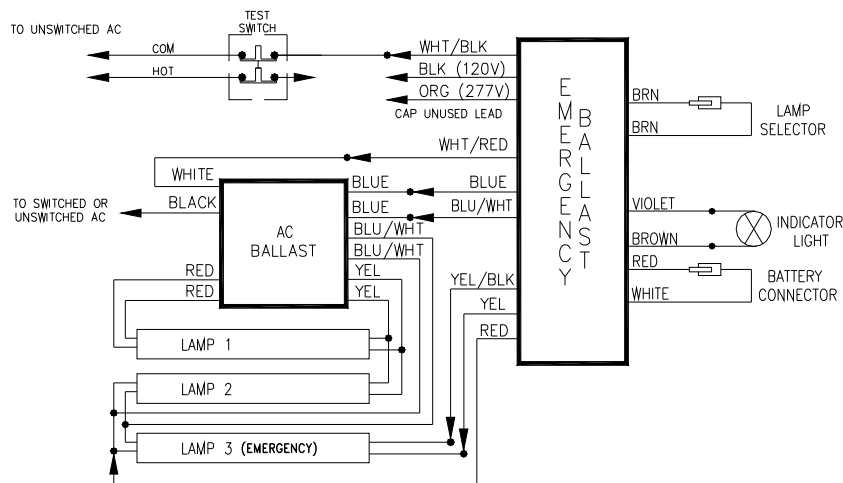

ONE LAMP EMERGENCY OPERATION CONT.

D. ONE (1) LAMP w/ INSTANT START BALLAST

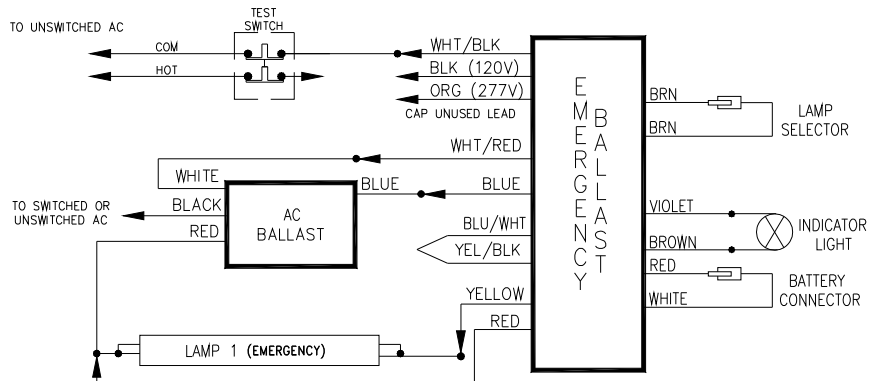

E. TWO (2) LAMP w/ INSTANT START BALLAST

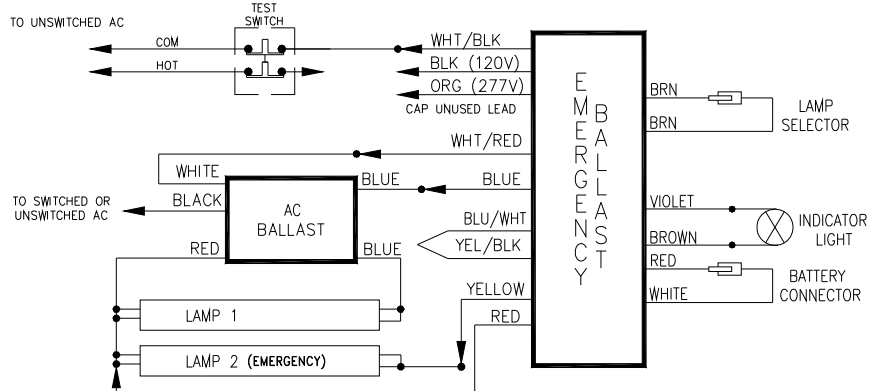

F. THREE (3) LAMP w/ INSTANT START BALLAST

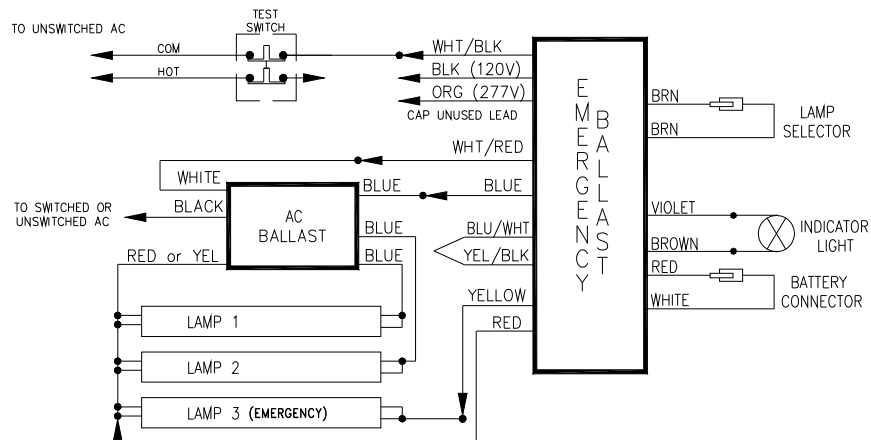

TWO LAMP EMERGENCY OPERATION

G. TWO (2) LAMP w/ RAPID START BALLAST

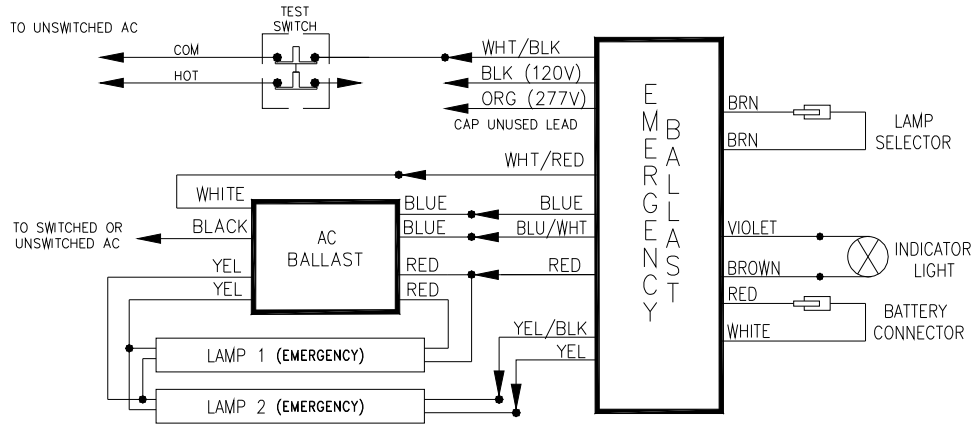

H. TWO (2) LAMP w/ INSTANT START BALLAST

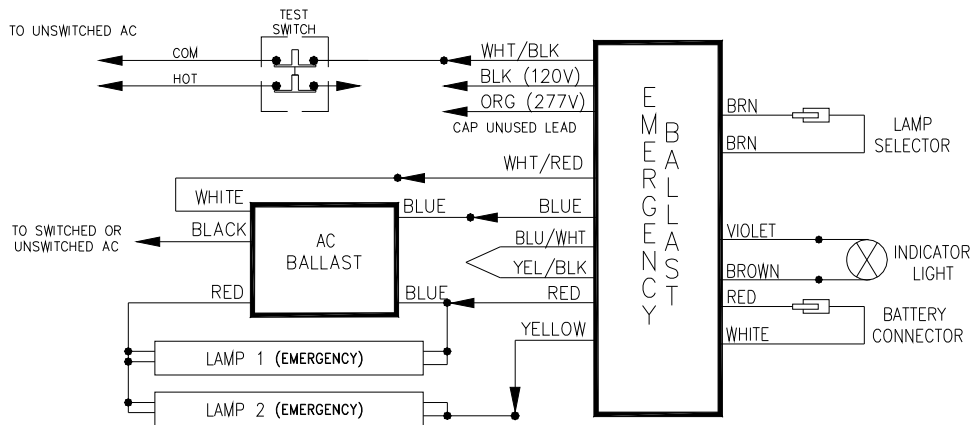

EMERGENCY ONLY OPERATION

I. ONE (1) LAMP w/o AC BALLAST

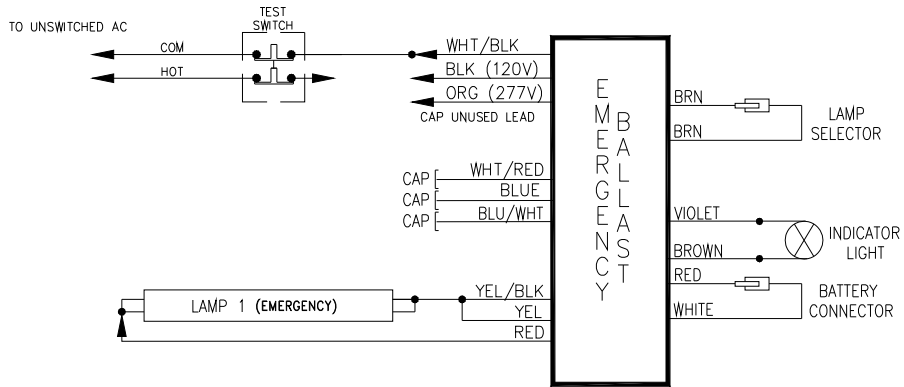

J. TWO (2) LAMP w/o AC BALLAST

