



LUMINATOR 6 & 12 VOLT LEAD AND NICAD

Service Questions Call: 910-259-1000

IMPORTANT SAFEGUARDS

When using electrical equipment, basic safety precautions should always be followed, including the following:

READ AND FOLLOW ALL SAFETY INSTRUCTIONS

All servicing should be performed by qualified personnel only.

Equipment should be mounted in locations and at heights where it will not be readily subjected to tampering by unauthorized personnel.

The use of accessory equipment not recommended by the manufacturer may cause an unsafe condition.

Do not use this equipment for other than intended use.

Do not let supply cords touch hot surfaces.

Do not mount near gas or electric heaters.

Caution: Halogen cycle lamp(s) are used in this equipment. To avoid shattering: Do not operate

LightGuard is a Philips group brand

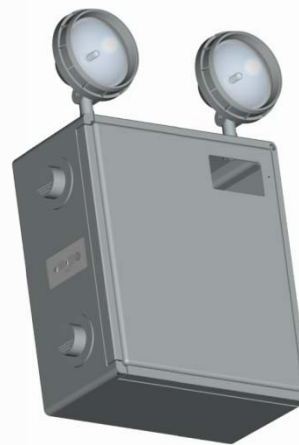

INSTALLATION AND OPERATING INSTRUCTIONS

lamp in excess of rated voltage, protect lamp against abrasion and scratches and against liquids when lamp is operating, dispose of lamp with care.

Halogen cycle lamps operate at high temperatures. Do not store or place flammable materials near lamp.

Use caution when servicing batteries. Battery acid can cause burns to skin and eyes. If acid is spilled on skin or eyes, flush acid with fresh water and contact a physician immediately.

CAUTION: To avoid electrical overload, total connected lamp load (factory and field installed) should not exceed output rating.

SAVE THESE INSTRUCTIONS

WARNING – Shut off AC power to branch circuits to which units will be connected. All wiring should be per N.E.C. Articles 501-4(b) and local codes.

To maintain warranty, equipment with batteries must be installed or placed on charge within prescribed period after shipment.

GENERAL INSTRUCTIONS

PHILIPS

MOUNTING INSTRUCTIONS

1. Prior to mounting to wall, determine easiest location for cable entry
2. Drill box to accommodate a water/dust tight compression fitting (See Figure 1).

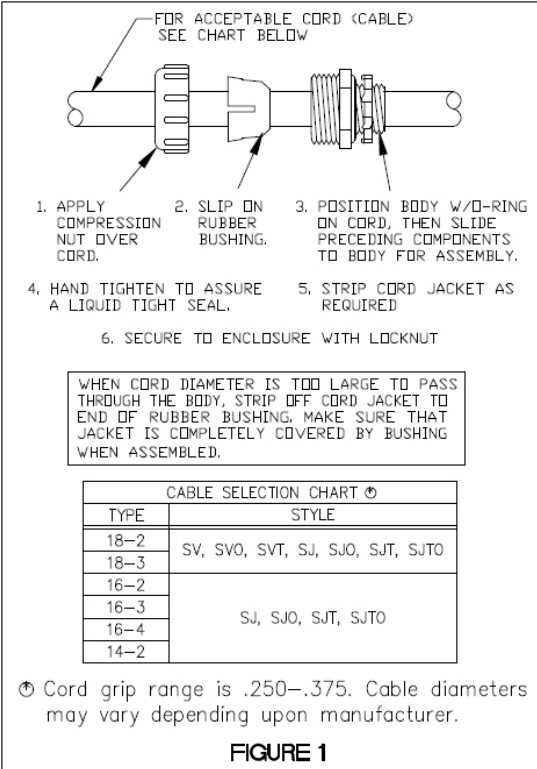

3. Mounting feet may be installed at this time using supplied with mounting feet kit. (See Figure 2).
4. Thread AC service wires through compression fitting (See Figure 1).

MOUNTING DIMENSIONS

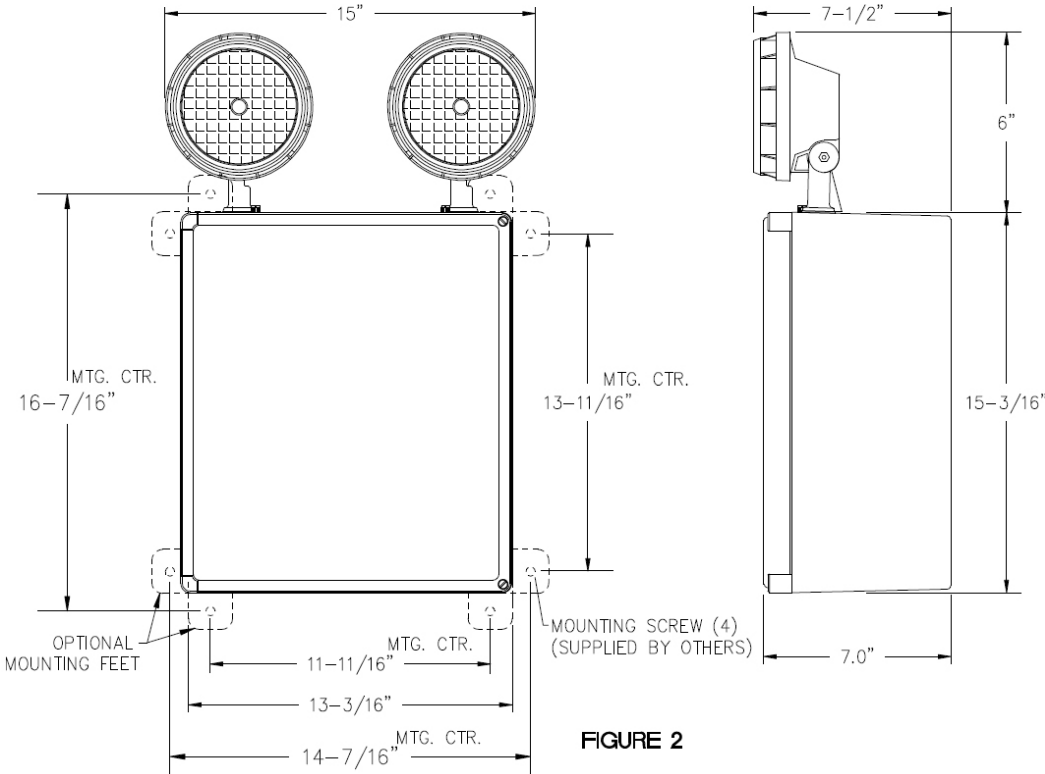

Hookup Instructions

1. Connect AC service to unit charger leads:
 - Blue wire = 277VAC
 - Black wire = 120VAC
 - White wire = Common
 - Green wire = Ground
 (Unused primary wire must be insulated to prevent shorting)
2. A dual load terminal block is provided for lamp hookup. Ensure total wattage of heads, both unit mounted and remote (if applicable), do not exceed unit rating. All remote loads should be wired to the terminal block at L1+/L2+ and L1-/L2- (See Figure 4). Use a wire gauge that limits voltage drop to an acceptable level (see “WIRING CALCULATIONS FOR VOLTAGE DROP PROTECTION”).
3. Adjust heads (if applicable) as follows: (See figure 4)
 - Rotation – Loosen head nut and rotate head to desired position. Retighten head nut. An anti-rotation screw has been provided to ensure proper rotation.
 - Angle – Loosen screw passing through head swivel sufficiently to allow internal teeth to disengage. Position head to desired angle.
 - Retighten both head nut and screw.
4. Connect battery(ies) to charger by inserting battery connector(s) onto batteries. (See figure 5).
5. Close cover and secure with provided screws (Qty. 2).

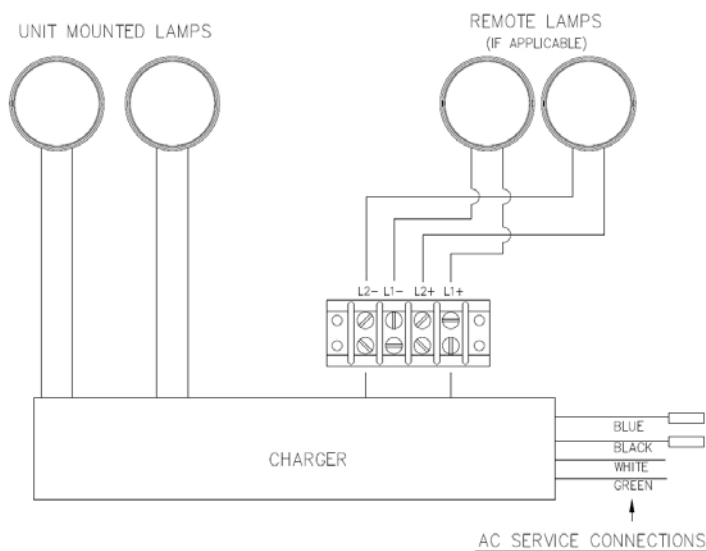

CONNECT REMOTE LOAD TO L1+/L2+ AND L1-/L2-
PER N.E.C. 501-4(b) AND 502-4(b) REQUIREMENTS.

FIGURE 3

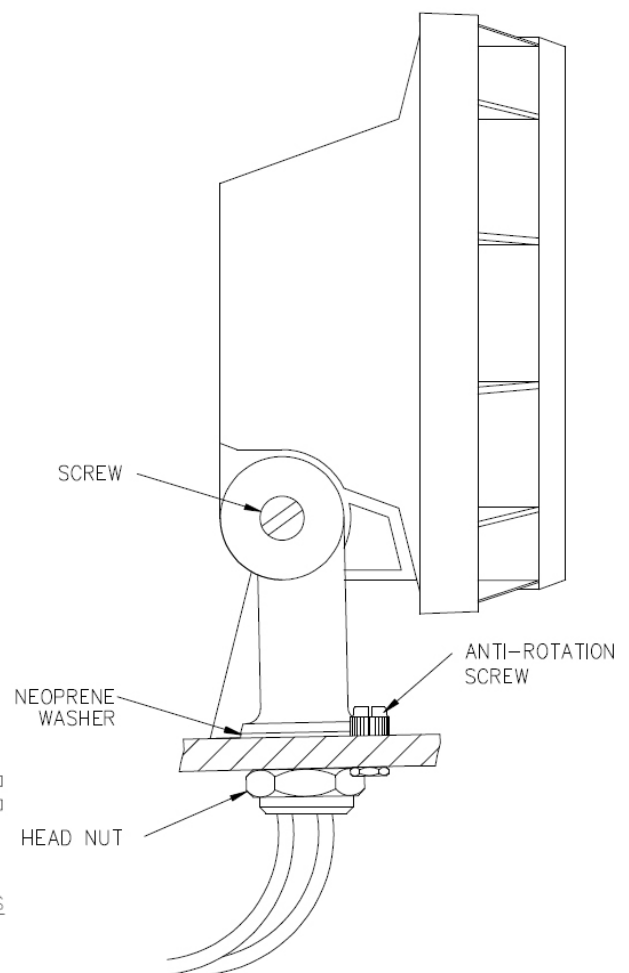
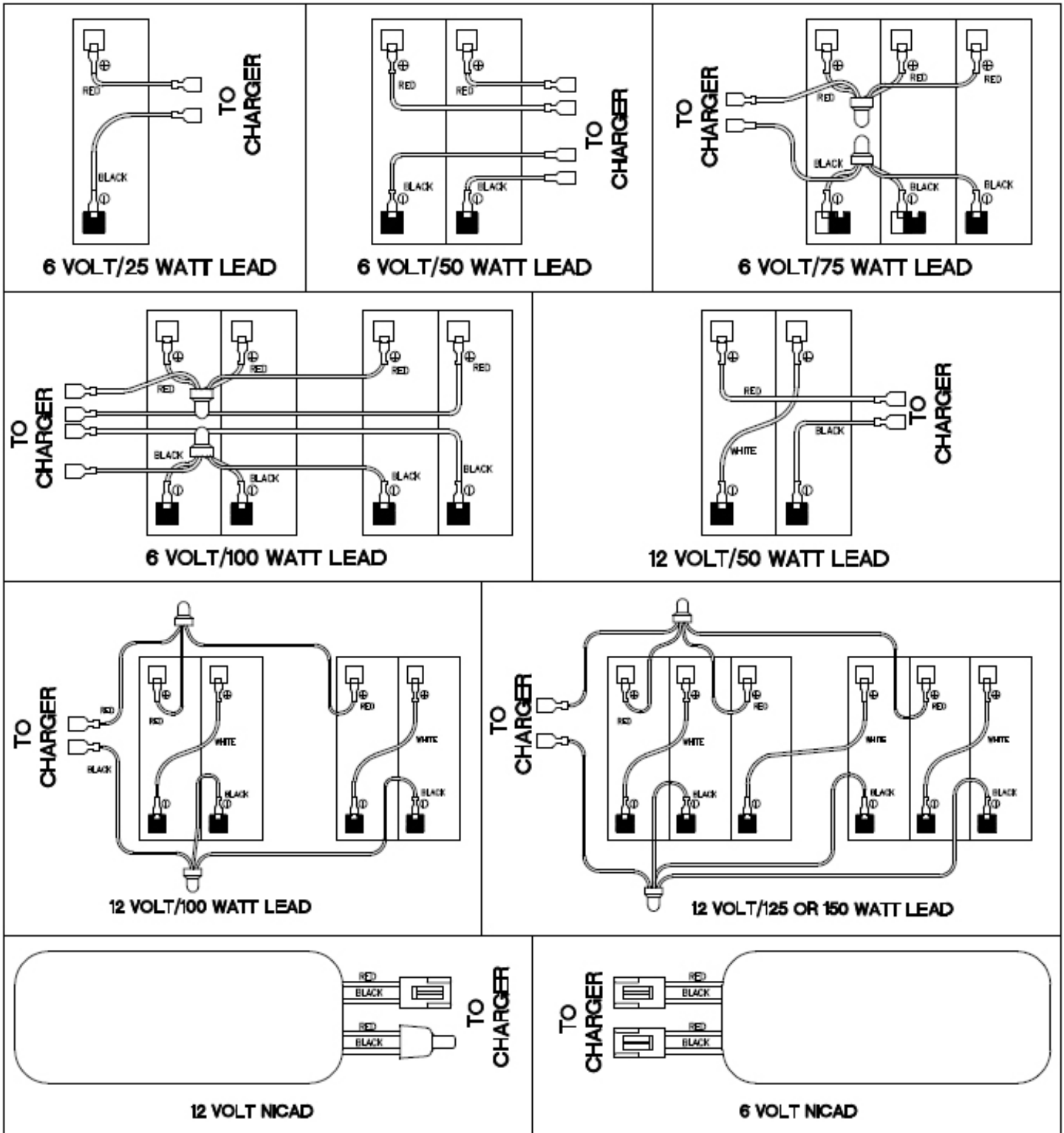
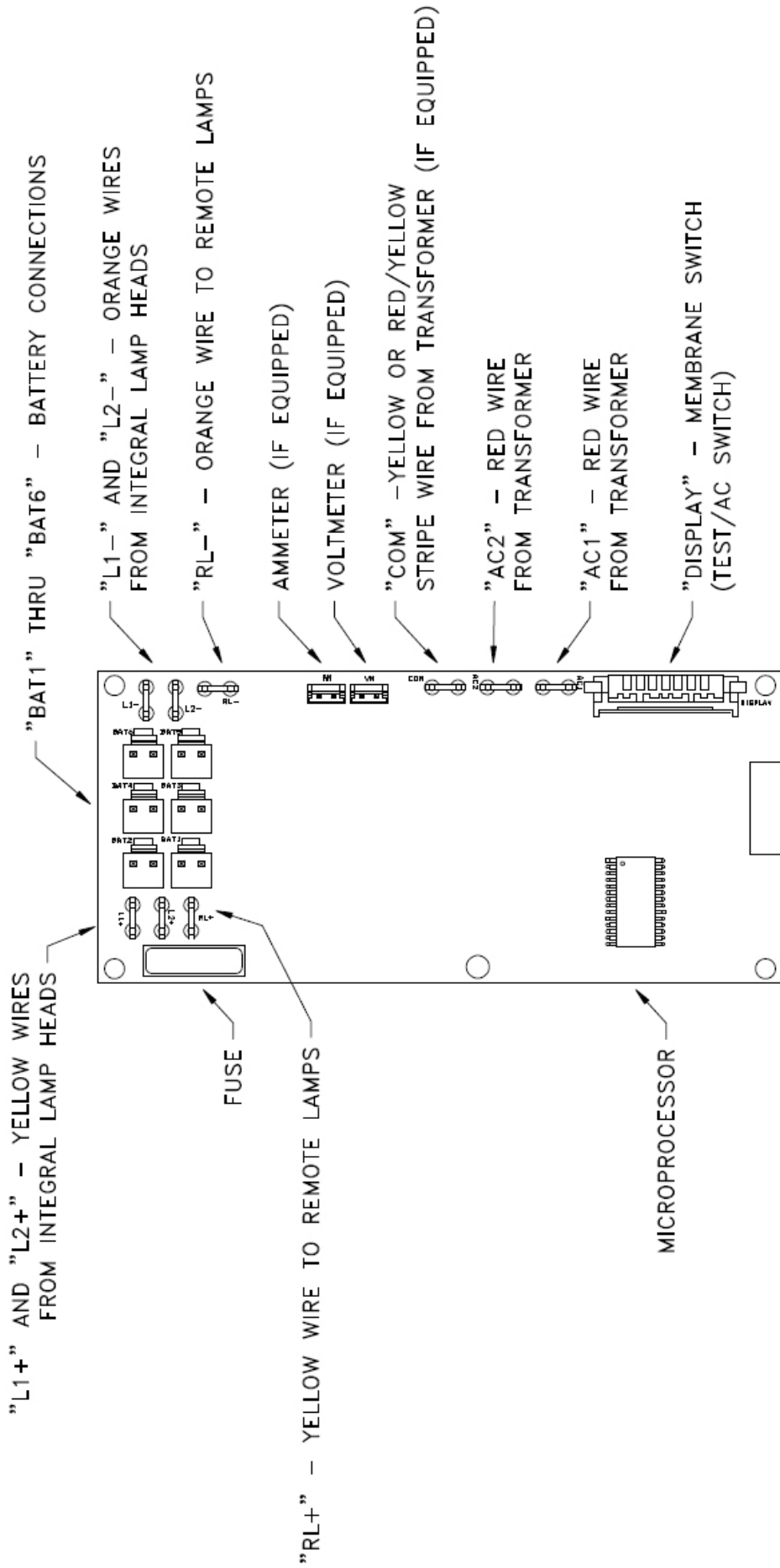

FIGURE 4



BATTERY HOOKUP CONFIGURATIONS

FIGURE 5



NICAD CHARGER BOARD

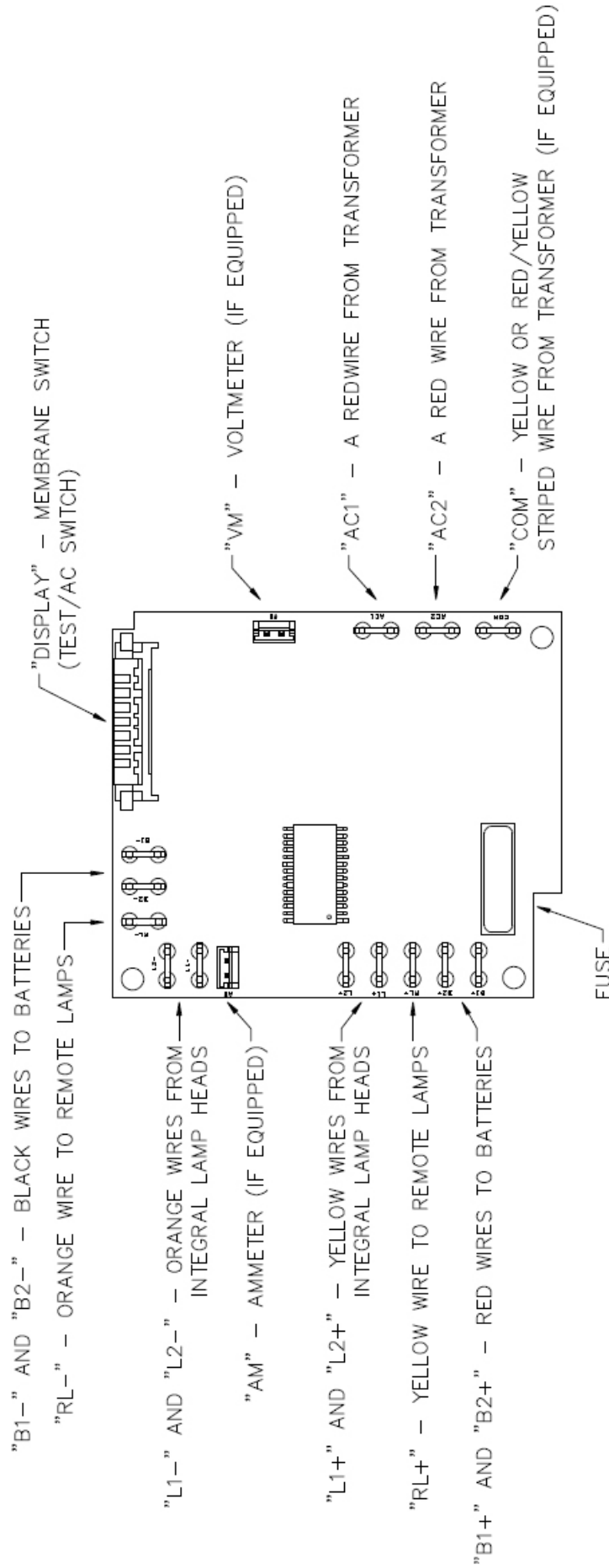

LEAD CALCIUM CHARGER BOARD 25 THROUGH 100 WATT UNITS

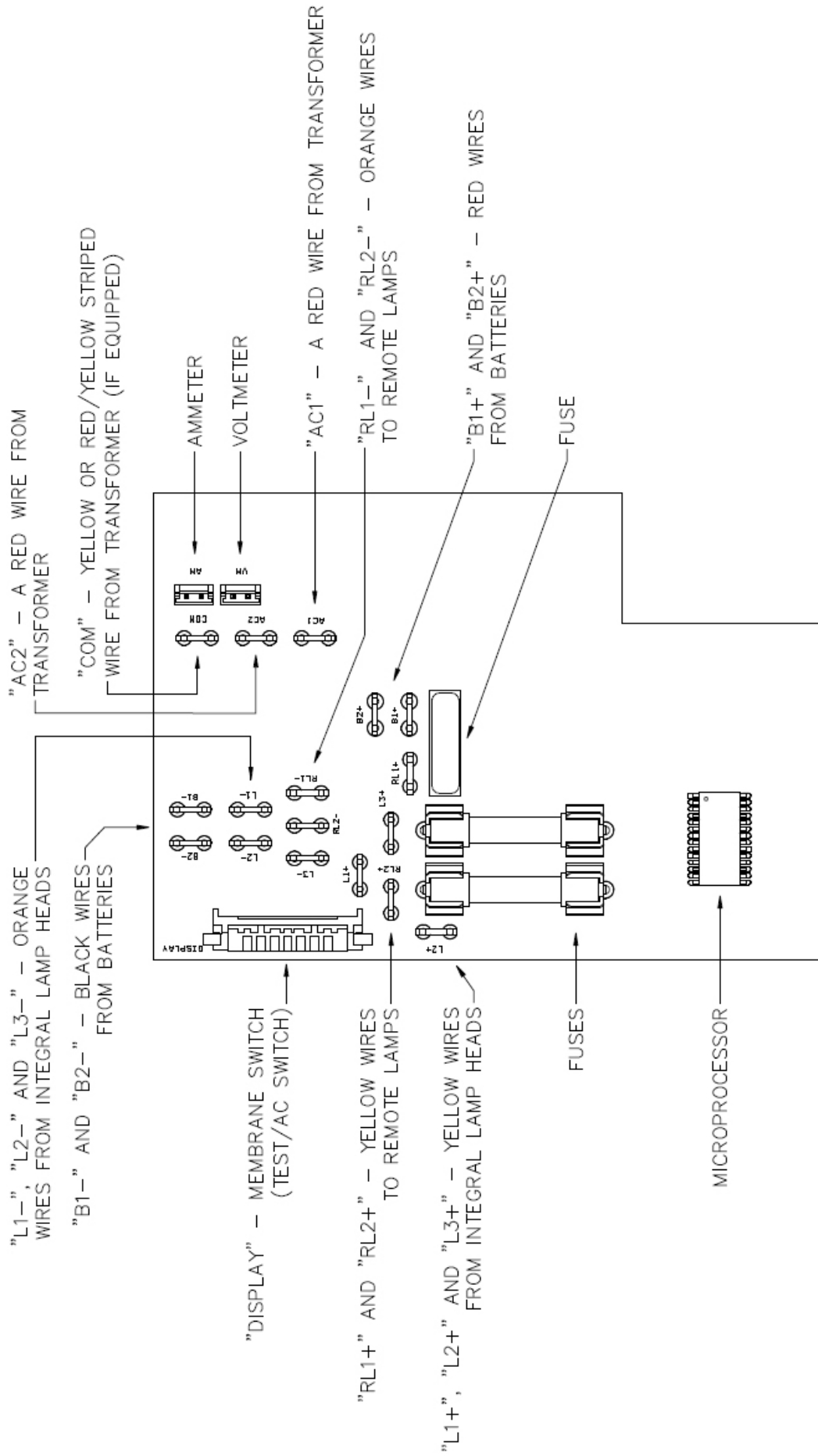

LEAD CALCIUM CHARGER BOARD 125 WATT AND UP UNITS

SMART CHARGER SYSTEM OPERATION

Normal Power-Up Sequence

At power-up, the red and green LED indicators will alternately flash for one to two seconds. Next, the unit will go through a “Power-Up Quick Test” with the green LED flashing quickly. If no power-up faults were detected, the green LED will then flash slowly for up to 36 hours to indicate that the battery is charging. If any faults were detected during the “Power-Up Quick Test”, these will be indicated by a flashing red LED indicator (see below for interpretation of flashing sequences). The red LED may be accompanied by a buzzer. This buzzer may be disabled by a short press of the test switch or by the “SILENCE ALARM” button on the remote tester and will remain disabled for a period of 196 hours. After the fault has been corrected, the red LED flash and buzzer will be cleared automatically and the unit will return to normal operation except in the case of lamp failure. Once relamping has been completed, perform a manual test to clear the fault.

Emergency Operation

Emergency operation occurs when AC power fails. The unit remains in this mode until AC power is restored. During emergency operation, both red and green LED indicators are disabled. Upon restoration of AC power, the green LED will flash for up to 36 hours to indicate that the unit is in battery charging mode.

User Interface

Green LED Indicator

- Steady On – AC power is present and battery is fully charged
- Slow Flash – Battery charging
- Fast Flash – Unit is performing an automatic or manually initiated self-test

Red LED Indicator

- Single Flash – Battery fault
- Double Flash – Lamp failure
- Triple Flash – Charger fault

(If more than one fault condition is present simultaneously, the red LED will flash each fault pattern in sequence, and then repeat)

Red and Green LED Indicators Together

- Fast flashing red and green – 277VAC applied to 120VAC input lead

Pushbutton Test Switch

- Long Press (over .5 seconds) – Transfers unit to emergency (battery) operation as long as button is depressed
- Short Press – Initiates various self tests
 - One Press – Cancel any self-test currently running
 - Two Presses – Start 1 minute self-test
 - Three Presses – Start 90 minute self-test
 - Seven presses – Forces a complete system reset

(The unit will allow up to seven 1 minute tests during the first 24 hours of operation. Allow at least 24 hours for battery charging before performing and extended amount of testing)

Buzzer – Sounds in unison with the flashing red LED if a fault is detected. May be disabled for up to 196 hours by a short press of the test switch.

IR receiver – Used with the optional hand-held IR remote tester to initiate or cancel manual testing.