



LF1000-4PST

Service Questions Call: 910-259-1131

IMPORTANT SAFEGUARDS

When using electrical equipment, basic safety precautions should always be followed, including the following:

READ AND FOLLOW ALL SAFETY INSTRUCTIONS

All servicing should be performed by qualified personnel only.

To prevent Electrical shock, do not connect emergency ballast battery connectors until installation is complete and AC power has been applied.

This product is designed for use in UL listed indoor fixtures only, except for those used in air handling, heated or hazardous locations.

Equipment should be mounted in locations and at heights where it will not be readily subjected to tampering by unauthorized personnel.

Do not use this equipment for other than intended use.

Do not use outdoors.

Do not let supply cords touch hot surfaces.

Do not mount near gas or electric heaters.

Do not install in areas of excessive moisture.

Do not use this equipment for other than its intended use.

Do not attempt to service the battery. Contact manufacturer for information on servicing equipment.

Ensure all power has been removed prior to start of installation.

Install in accordance with National Electrical Code and local code guidelines.

SAVE THESE INSTRUCTIONS

PRODUCT DESCRIPTION

The LF1000-4PST Emergency ballast requires an unswitched 120V or 277V AC input and is designed for use with one 13-42W or two 13-26W compact fluorescent lamps. The LF1000-4PST provides a minimum of 90 minutes of emergency operation in accordance with UL924 requirements. A momentary test switch, charging indicator light and test/monitor plate are supplied with the LF1000-4PST.

The LF1000-4PST also contains a Control/ Monitor circuit which automatically performs periodic discharge testing (see Self Test Operation section).

WARNING

ENSURE ALL AC POWER HAS BEEN REMOVED FROM
FIXTURE BEFORE BEGINNING INSTALLATION

INSTALLATION

CAUTION: TO PREVENT ELECTRICAL SHOCK, BATTERY CONNECTORS SHOULD NOT BE CONNECTED UNTIL INSTALLATION IS COMPLETE AND AC POWER HAS BEEN APPLIED TO EMERGENCY BALLAST.

1. Install the LF1000-4PST emergency ballast (see Illustration 1) near the fixture, or remotely, one half of the distance the AC ballast manufacturer recommends remote mounting the AC ballast, or up to 50 feet, whichever is less. If no AC ballast is used, the LF1000-4PST may be mounted up to 50 feet from the fixture.
2. Mount the test/monitor plate in the ceiling, next to the fixture, or remotely up to 50 feet from the fixture.

NOTE: Switch box is not supplied

Caution: Test switch must be installed in line with the unswitched AC source. On switched fixtures, an additional unswitched hot wire, from the same branch circuit, must be supplied to the LF1000-4PST (see wiring diagrams).

3. Install the momentary test switch and charging indicator in the test/monitor plate.

INSTALLATION CONT.

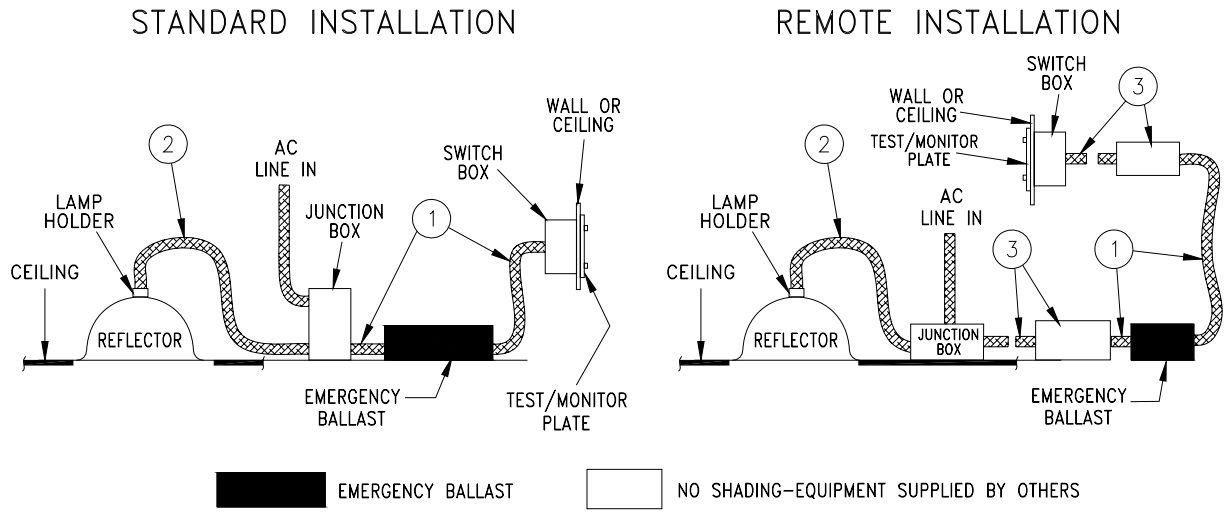

- ① -Flexible conduit (supplied) to connect ballast wires.
- ② -Existing conduit to run existing wires to lamp holder (AC ballast on junction box). If AC ballast is on reflector, run yellow/black, blue, and blue/white wires from emergency ballast through this conduit.
- ③ -Conduit and junction box (not supplied), necessary for remote installation.

4. Using the wiring diagrams provided, make all connections in accordance with the National Electric Code and any local requirements.
5. In a readily visible location, install the label “Caution – this unit has more than one power connection point. To reduce the risk of shock, disconnect both the branch circuit breakers or fuses and emergency power supplies before servicing.”
6. Upon completion of installation, apply AC power to the LF1000-4PST and connect the battery connectors.

NOTE: This product is equipped with an Audible alarm. To disable, cut Red/White wire and cap both ends.

OPERATION

1. After the AC power has been applied to the LF1000-4PST, verify the charging indicator is illuminated. If not, refer to wiring diagrams and recheck wiring.
2. Allow the LF1000-4PST battery to charge for one hour before performing any further testing. The LF1000-4PST should be allowed to charge for a minimum of 72 hours before a full discharge test is performed.
3. After the initial one hour charge, a short term discharge test may be performed by pressing and holding the momentary test switch.
4. Verify the lamp(s) is lit, based on the chosen configuration, at a reduced illumination level, while the switch remains pressed.
5. If the fixture is used for emergency operation only, release the test switch and the lamp(s) will go out. If the fixture is used for normal and emergency operation, upon release of the test switch, the lamp(s) will remain out for approximately 4 seconds before returning to normal illumination levels.
6. If a full discharge test is being performed, remove AC power and verify the lamp(s) is illuminated, at a reduced level, for a minimum of 90 minutes, in accordance with UL924.
7. This equipment continually monitors the charging current and battery voltage. Should the unit detect an abnormal condition, the indicator light will flash and the audible alarm will sound, unless it has been disabled.

MAINTENANCE

Although no routine maintenance is required for the LF1000-4PST, the following tests should be performed periodically to maintain compliance with national and local codes.

1. Monthly, visually check to see that the charging indicator is illuminated and not flashing indicating an abnormal condition.
2. Once a year, conduct a 90 minute discharge test (see OPERATION section) to verify proper operation.

WIRING DIAGRAMS

The following are typical wiring diagrams. Emergency and AC ballast must be fed from the same branch circuit. Please consult the factory for wiring diagrams not shown

TABLE 1

LAMP TYPE	BASE TYPE	WATTAGE	# OF LAMPS EMERGENCY	BROWN CONNECTOR
T8	SINGLE OR BI-PIN	17-32W	1	CLOSED
LONG COMPACT	4 PIN (2G11)	18-39W	1	
		40-55W	1	
COMPACT	4 PIN (G24Qq GX24q)	13-42W	1	OPEN
		13-26W	2	

ONE LAMP EMERGENCY OPERATION

A. ONE (1) FOUR PIN COMPACT LAMP RAPID START BALLAST

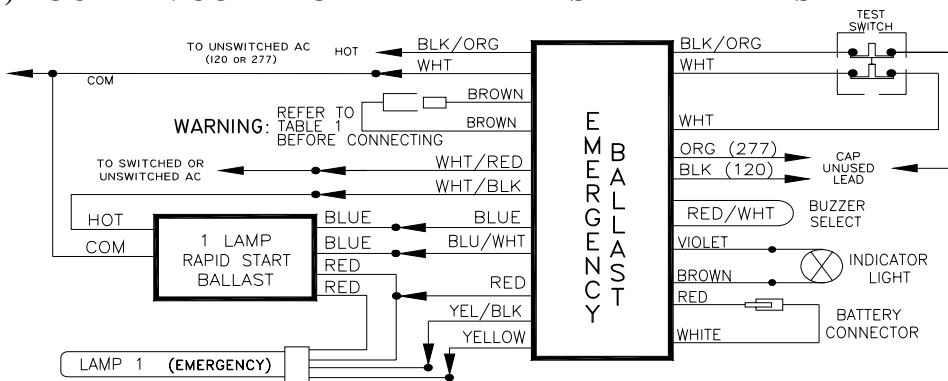

B. TWO (2) FOUR PIN COMPACT LAMP RAPID START BALLAST

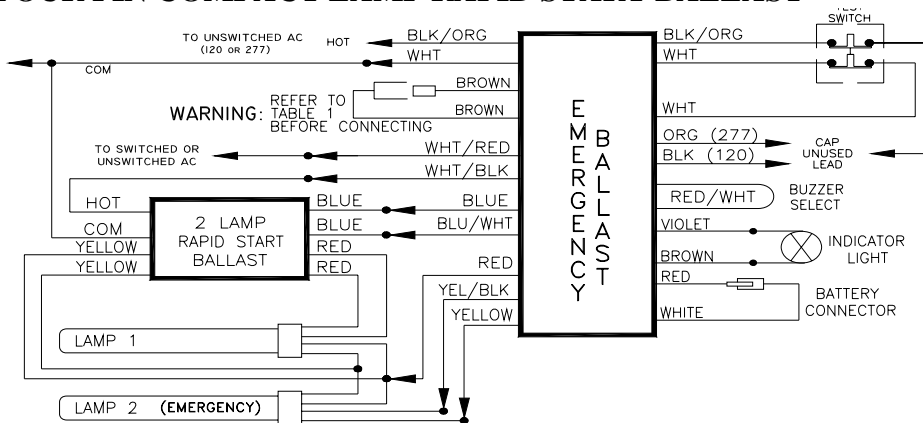

ONE LAMP EMERGENCY OPERATION CONT.

C. ONE (1) LAMP RAPID START BALLAST

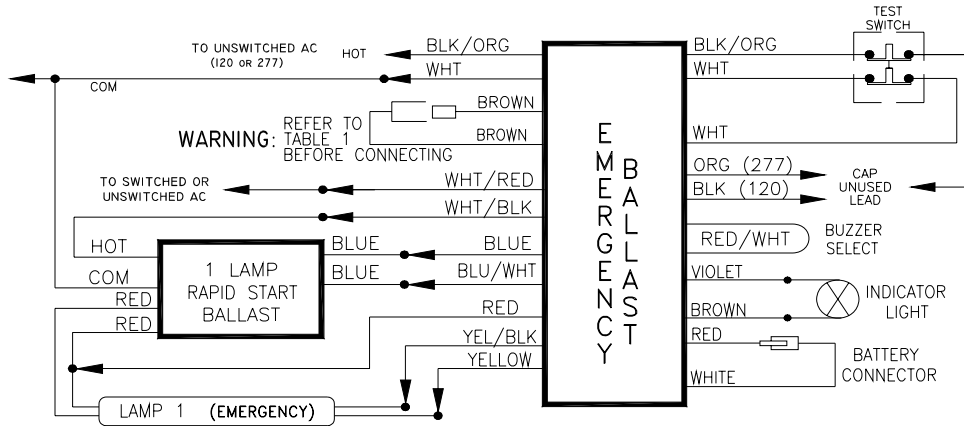

D. ONE (1) FOUR PIN COMPACT LAMP INSTANT START BALLAST

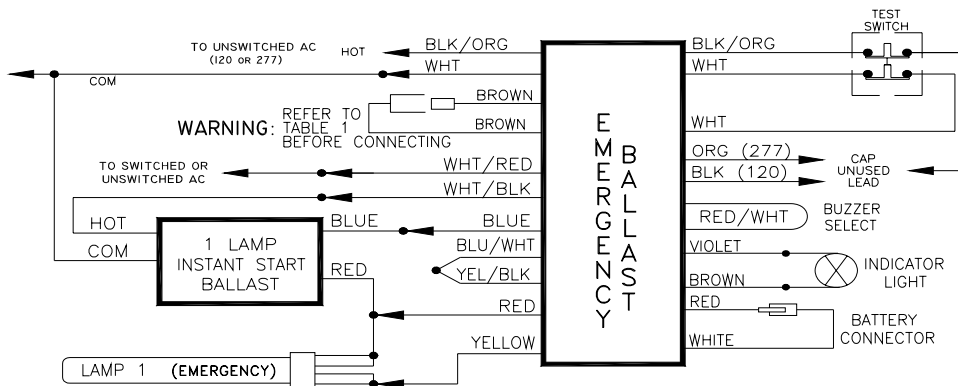

E. TWO (2) FOUR PIN COMPACT LAMP INSTANT START BALLAST

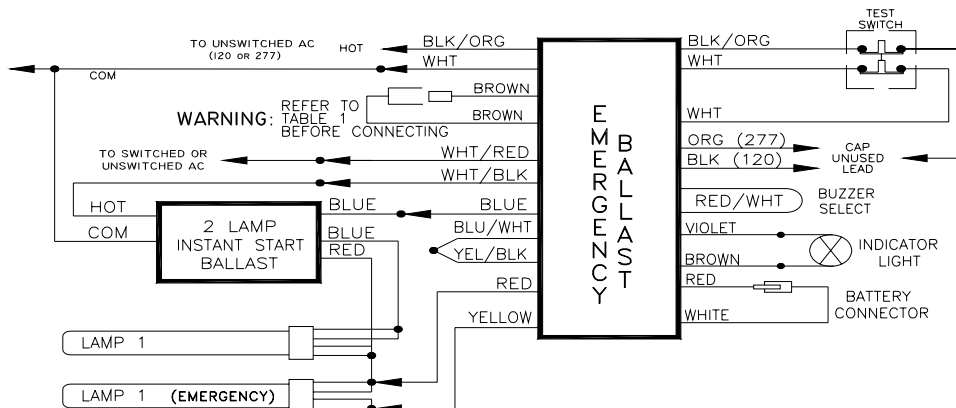

TWO LAMP EMERGENCY OPERATION

F. TWO (2) FOUR PIN COMPACT LAMP RAPID START BALLAST

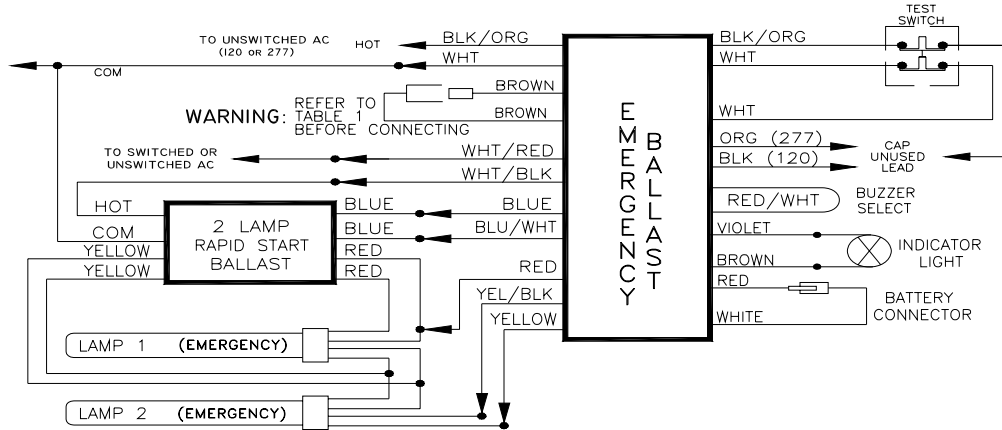

WIRING DIAGRAMS FOR EMERGENCY ONLY FIXTURES

G. ONE (1) FOUR PIN COMPACT LAMP WITHOUT AC BALLAST

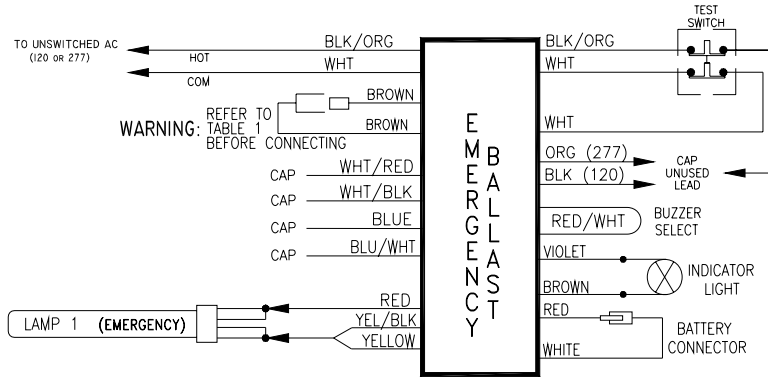

H. TWO (2) FOUR PIN COMPACT LAMP WITHOUT AC BALLAST

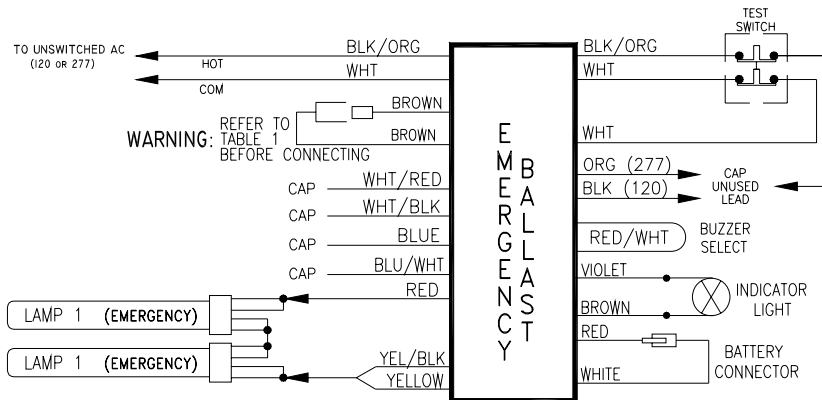

SELF-TESTING OPERATION

The unit contains a control/monitor circuit that automatically performs a 30 second discharge test every 30 days, and a full 90 minute discharge test once a year. During routine testing, the unit simulates an AC power failure causing the unit to automatically switch to emergency mode. The unit will monitor the operation of the lamps, battery voltage, charge current, and emergency duration. If the emergency system functions properly, then the unit will return to normal mode. Should the unit detect any problems, the indicator light will flash continually and the audible alarm will sound 4 times every 30 seconds until the condition has been corrected or the unit passes the next test.

MAINTENANCE

The unit automatically performs required routine testing. Results are reported to maintenance personnel via the indicator light and audible alarm.

NOTE:

* To disconnect audible alarm cut red/white looped wire. Cap the end of the wires.

If optional audible alarm is disabled, maintenance personnel should periodically check the indicator light. If the indicator light is flashing, go through all steps of Troubleshooting Guide.

TROUBLESHOOTING GUIDE

STATUS INDICATORS		PROBLEM	CORRECTION
INDICATOR LIGHT	AUDIBLE ALARM		
Light on steady, not blinking	No beeping	None	Unit is operating correctly
Flashing 1/2 second intervals	Beeping 1/2 second intervals	Line voltage; incorrect installation	Check line voltage. For 120VAC use black as hot; for 277VAC use orange as hot wire lead.
Flashing 1/2 second intervals	Beeping 4 times every 30 seconds	Failed scheduled self-test	<ol style="list-style-type: none"> 1. Check to make sure lamps are good (operational and specified for the unit) and in place. 2. Check to see if brown connector is properly used. (See Table 1) 3. Check that fixture wiring is in accordance with proper wiring diagram. 4. Allow unit to charge for 24 hours. If flashing/beeping continues emergency ballast should be replaced.

A failure status will be reset 10 minutes after the problem has been corrected.

NOTE: It is normal for the indicator light to remain off for a few minutes on initial startup or after a very long power outage (discharge), as the battery voltage rises to normal range. Refer to Troubleshooting Guide if this condition persists.