

IMPORTANT SAFEGUARDS

When using electrical equipment, basic safety precautions should always be followed, including the following:

READ AND FOLLOW ALL SAFETY INSTRUCTIONS

All servicing should be performed by qualified personnel only.

Do not use this equipment outdoors.

Equipment should be mounted in locations and at heights where it will not readily be subjected to tampering by unauthorized personnel.

The use of accessory equipment not recommended by the manufacturer may cause an unsafe condition.

Do not let power supply cords touch hot surfaces.

Do not mount near gas or electric heaters.

CAUTION: Halogen cycle lamp(s) are used in this equipment. To avoid shattering: Do not operate lamp in excess of rated voltage, protect lamp against abrasion and scratches and against liquids when lamp is operating, dispose of lamp with care.

Halogen cycle lamps operate at high temperatures. Do not store or place flammable materials near lamp.

CAUTION: To avoid electrical overload, total connected lamp load (factory and field installed) should not exceed output rating. For 8 hour run time total connected lamp load should not exceed 24 watts.

Do not use this equipment for other than intended use.

SAVE THESE INSTRUCTIONS

WARNING

Shut off AC power to branch circuits to which units will be connected. All wiring should be per National Electrical Code and local regulations.

INSTALLATION

(See Figure 1 for cabinet dimensions)

The L100 is suitable for 120VAC or 277VAC, 60Hz operation.

Use only battery type 100-1-226. Using plastic sling packed around battery, remove from carton. Install in unit with red terminal lead on right when facing unit.

1. Open cover and attach lamp heads to cabinet as required.
2. Remove appropriate cabinet knockout to accept AC power.
3. Remove keyway knockouts (2) if cabinet is to be mounted to wall.
4. Mount cabinet to wall or use optional mounting plate (Part Number MBB)
5. Connect lamphead leads to terminals at printed circuit module marked LOAD (+) and (-).
6. If remote lamps are used, they should also be connected at this time.
7. Make electrical hookups at this time as follows:

120 VAC OPERATION

White Wire - Common
 Black Wire - 120V Line
 Green Wire - Ground

277 VAC OPERATION

White Wire - Common
 Red Wire - 277V Line
 Green Wire - Ground

NOTE:

Unused primary wire must be insulated to prevent shorting.

8. Connect red wire terminal from battery to B(+) terminal on P.C. Board assembly.
9. Remove and discard the black wire provided with the battery. Locate the 18" black wire assembly connected to the B(-) terminal on the P.C. Board assembly and connect it to the B(-) terminal on the battery.

NOTE: Batteries must be connected exactly as indicated or equipment failure will result.

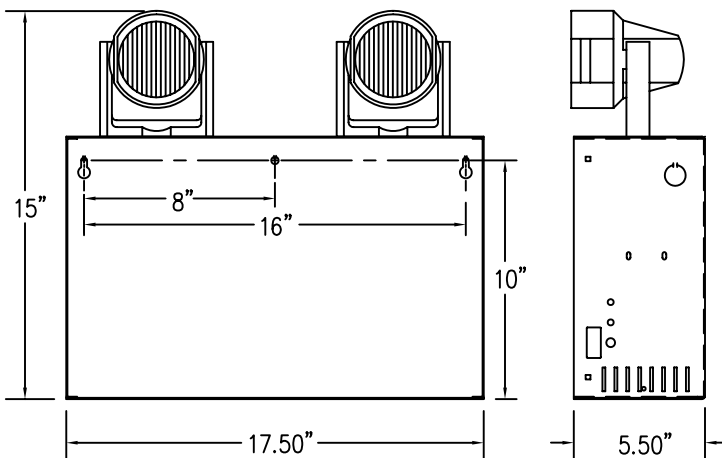

FIGURE 1

OPERATION

For emergency protection place READY switch (black plastic switch on printed circuit board) in the READY position. The READY light on the front panel will be lit.

READY switch can be placed in STANDBY when emergency lighting protection is not required, e.g. during a power failure when the need for light is over, or prior to planned power outages to prevent excessive battery discharges. Do not disconnect the AC as this disconnects the charger.

Leave AC connected for a minimum of 24 hours before performing any abbreviated testing. Full recharge of battery may take up to one (1) week.

The solid state pulse type charger continually senses the battery voltage and will provide a rate of charge depending on the battery's state of charge. After any discharge, the battery is automatically returned to full charge and maintained at that level.

A fully charged battery will be indicated by a pulsating red CHARGE light. After operation of TEST switch or after a power outage, the red CHARGE light will glow brightly, indicating that the battery is receiving a high rate of charge. The CHARGE light will be lit brightly for only a few minutes at a time unless the battery has been discharged by an extended power outage.

MAINTENANCE

The L100 unit should be tested periodically by pressing the TEST switch and checking that all lamps are lit.

If the emergency lights do not stay on for more than a few minutes during a power failure, the battery may need to be replaced. A new battery may be obtained from your Lightguard distributor.

See label on inside of door for correct battery part number.

TROUBLE SHOOTING CHART

SYMPTOM	POSSIBLE CAUSE	PROCEDURE
READY Indicator on and Charge Indicator off	Blown fuse Battery leads disconnected or broken Defective Charger Module AC connected for 277V on 120V service	Replace fuse Connect battery or Repair leads Replace Charger Module Make proper connection
READY Indicator off and Charge Indicator on	Standby/Ready switch in standby position Battery connections reversed Defective Charger Module	Place switch in Ready position Reverse battery connections Replace Charger Module
READY Indicator off and Charge Indicator off	AC service off Defective Charger Module	Reconnect or turn on AC service Replace Charger Module
READY Indicator on but no lights when TEST switch pressed	Blown fuse Lamps not connected AC connected for 277V on 120V service Low AC service	Replace fuse Connect lamps Make proper connection Correct electrical service
READY Indicator on, Charge Indicator on and lamps on	Brownout Defective Charger Module	Check AC service Replace Charger Module
Lamps not on for rated time	Low Battery Blown fuse Defective Charger Module Defective Battery	Charge for 24 hours and retest Replace fuse Replace Charger Module Replace Battery